



METAL C
COMPONENTES AUTOMOTIVOS

CATÁLOGO 2024

ÍNDICE

LINHA SUSPENSÃO	03
LINHA RESERVATÓRIOS DE AR	32
CAIXAS	33
PARA-CHOQUES	34
PROTETOR LATERAL	36
SUPORTES DE PARALAMA	38
COMPONENTES.....	39
LINHA CAÇAMBA/BASCULANTE	42
LINHA TRAVESSAS	43
LINHA RANDON	44
LINHA GUERRA	55
LINHA NOMA	64
LINHA LIBRELATO	70
LINHA FACCHINI	76
INFORMAÇÕES	80

COMPATÍVEL COM RANDON



SUPORE DIANTEIRO
CARRETA MOD 2000
SP552



SUPORE DIANTEIRO
CARRETA MOD 2008
SP553



SUPORE CENTRAL
CARRETA MOD 2000
SP554



SUPORE CENTRAL
CARRETA MOD 2008
SP555



SUPORE GUIA CENTRO
LATERAL CARRETA
MOD 2008
SP670



SUPORE TRASEIRO
CARRETA MOD 2000
SP556



SUPORE CENTRAL
SUSPENSÃO
DISTANCIADA BUCHA
MOLECULAR
SP649



SUPORE CENTRAL
SUSPENSÃO
DISTANCIADA PINO 50mm
C/MANCAL
SP650



SUPORE SUPERIOR
SUSPENSÃO REBAIXADA
SP881



SUPORE CENTRAL
SUSPENSÃO REBAIXADA
P/PINO 50mm C/MANCAL
SP882



SUPORE TRASEIRO
SUSPENSÃO REBAIXADA
SP883



SUPORE DIANTEIRO
SUSPENSÃO REBAIXADA
SP884



SUPORE CENTRAL
SUSPENSÃO
DISTANCIADA BRAÇO
EQUALIZADOR
SP880



BALANCA SUSPENSÃO
DISTANCIADA BRAÇO
EQUALIZADOR BUCHA
LUBFREE
SP879



PARAFUSO SEXT M16x130mm 8.8
C/PORCA TRAVANTE ZB P/BALANÇA
SP807 (06 unidades)

PARAFUSO SEXT M24x140mm 8.8
C/PORCA TRAVANTE ZB P/TENSOR
SP808 (06 unidades)

PARAFUSO SEXT M16x150mm 8.8
C/PORCA TRAVANTE ZB P/SAPATA
SP809 (06 unidades)

PARAFUSO SEXT M16x80mm 8.8
C/PORCA TRAVANTE ZB P/PONTEIRA
TENSOR E BUCHA MOLECULAR
SP810 (06 unidades)

PARAFUSO SEXT M16x50mm 8.8 ZB
C/PORCA TRAVANTE
SP930 (06 unidades)

COMPATÍVEL COM RANDON



**BALANÇA ASA DELTA
SOLDADA P/PINO
Ø 50,00mm TRUCK**
SP470 - ch. 8,00mm



**BALANÇA ASA DELTA
SOLDADA P/PINO Ø 60,00mm**
SP472A - ch. 8,00mm



**BALANÇA ASA DELTA
ESTAMPADA P/PINO
Ø 50,00mm**
SP399 - ch. 6,35mm



**BALANÇA ASA DELTA
ESTAMPADA P/PINO Ø 50,00mm**
SP452 - ch. 8,00mm



**BALANÇA ASA DELTA
SOLDADA P/PINO Ø 50,00mm**
SP471 - ch. 8,00mm

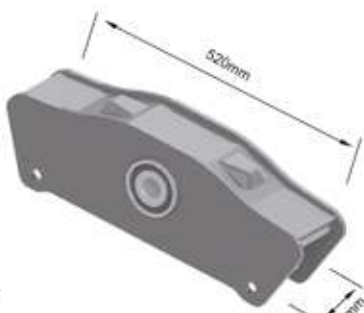

**BALANÇA ASA DELTA
SOLDADA C/BUCHA
LUBFREE 2011**
SP443A - ch. 8,00mm
SP443 - ch. 8,00mm - SEM BUCHA



**BALANÇA ASA DELTA
SOLDADA C/BUCHA
LUBFREE 2007**
SP648A - ch. 8,00mm
SP648 - ch. 8,00mm - SEM BUCHA



**BALANÇA ASA DELTA
SOLDADA P/PINO Ø 50,00mm
FLORESTAL**
SP638 - ch. 8,00mm

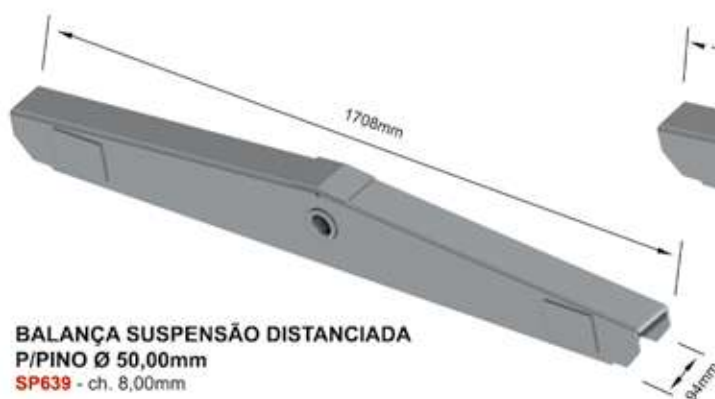

**BALANÇA SUSPENSÃO DISTANCIADA
P/PINO Ø 50,00mm**
SP639 - ch. 8,00mm



**BALANÇA SUSPENSÃO DISTANCIADA
C/BUCHA LUBFREE 2011**
SP640A - ch. 8,00mm
SP640 - ch. 8,00mm - SEM BUCHA



**SAPATA DESLIZANTE
DA ESFREGA**
SP473 - Corpo c/chapa 9,50mm
SP473A - Corpo c/chapa 6,35mm
Esfrega c/chapa 15,88mm



**SAPATA DESLIZANTE
DA ESFREGA**
SP475 - Corpo c/chapa 9,50mm
SP475A - Corpo c/chapa 6,35mm
Esfrega c/chapa 12,70mm



**SAPATA DESLIZANTE
DA ESFREGA C/LATERAL
ESTAMPADA**
SP541 - Corpo c/chapa 6,35mm
Esfrega c/chapa 15,88mm



**SAPATA 112mm
P/EIXO MACIÇO**
SP543

COMPATÍVEL COM RANDON



**SAPATA P/EIXO REDONDO
CARRETA 2000**
SP542



**SAPATA P/EIXO
RETANGULAR**
SP544



**SAPATA DESLIZANTE DA
ESFREGA SUSPENSYS FASE 1**
SP674 - Corpo c/chapa 4,25mm
Esfrega c/chapa 12,70mm



**SAPATA DESLIZANTE DA
ESFREGA SUSPENSYS FASE 2**
SP675 - Corpo c/chapa 6,35mm
Esfrega c/chapa 12,70mm



**PINO DA BALANÇA
CARRETA TEMP**
Ø 50,00x203mm
SP493
SP493A - sem têmpera



**PINO DA BALANÇA
CARRETA TEMP**
Ø 60,00x225mm
SP492
SP492A - sem têmpera



**PINO DA BALANÇA
CARRETA TEMP**
Ø 60,00x225mm
C/MANCAL
SP491
SP491A - sem têmpera



**PINO CÔNICO P/MANCAL
C/PORCA 98mm CARRETA**
SP503
(10 unidades)



**PINO DA BALANÇA
BUCHA MOLECULAR**
Ø M30x190mm C/PORCA
SP656



**TENSOR FIXO 480mm
CARRETA 2002 FUNDIDO**
SP560



**TENSOR FIXO
CARRETA SOLDADO**
SP545 - 480mm - 2002
SP545A - 532mm - 2008
SP545B - 360mm - 2000



**FUSO TENSOR REGULÁVEL
P/CARRETA 315mm**
SP563



**PONTEIRA DO TENSOR
CARRETA FUNDIDA**
SP559D - DIREITO
SP559E - ESQUERDO



**SEMI MANCAL
P/PINO Ø 60,00mm**
SP499
(20 unidades)



**MANCAL SUPORTE
CENTRAL P/PINO**
Ø 50,00mm
SP502
(20 unidades)



BUCHA TEMPERADA
Ø INTERNO 50,20mm
SP444
(10 unidades)



BUCHA TEMPERADA
Ø INTERNO 60,20mm
SP532
(10 unidades)



**BUCHA MOLECULAR
DA BALANÇA**
SP615



**BUCHA MOLECULAR
TENSOR CARRETA
2000**
SP557

COMPATÍVEL COM GUERRA



SUPORE DIANTEIRO
SP549
SUPORE GUIA
SUSPENSÃO DISTANCIADA
SP877



**SUPORE CENTRAL
CARRETA**
SP550



**SUPORE CENTRAL
P/1º BITREM**
SP606



**SUPORE SUSPENSÃO
CENTRAL LUBFREE**
SP905D - DIREITO
SP905E - ESQUERDO



**SUPORE TRASEIRO
CARRETA**
SP551



**BALANÇA ASA DELTA
ESTAMPADA P/PINO Ø 50,00mm
P/CARRETA**
SP468 - ch. 8,00mm

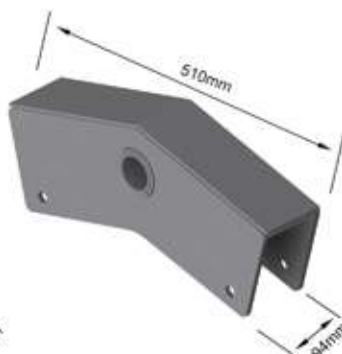

**BALANÇA ASA DELTA
SOLDADA P/PINO Ø 50,00mm
P/CARRETA**
SP487 - ch. 8,00mm



**BALANÇA SOLDADA
P/PINO Ø 50,00mm
P/TRUCK**
SP476 - ch. 8,00mm



**BALANÇA ASA DELTA
ESTAMPADA C/BUCHA
LUBFREE**
SP928 - ch. 6,35mm



**BALANÇA SUSPENSÃO
DISTANCIADA P/PINO 50,00mm**
SP647 - ch. 8,00mm



**SAPATA SUPERIOR P/EIXO
REDONDO**
SP547



**SAPATA SUPERIOR P/EIXO
RETANGULAR**
SP548



**SAPATA DESLIZANTE DA
ESFREGA A PARTIR DE 2004**
SP474 - Corpo c/chapa 9,50mm
SP474A - Corpo c/chapa 6,35mm
Esfrega c/chapa 12,70mm



**FUSO TENSOR REGULÁVEL
P/CARRETA 315mm**
SP563

COMPATÍVEL COM GUERRA



**TENSOR FIXO 435mm
SOLDADO P/CARRETA**
SP546



**PONTEIRA DO TENSOR
FUNDIDA P/CARRETA**
SP564D - DIREITO
SP564E - ESQUERDO



**BUCHA MOLECULAR
TENSOR C/PINO**
SP562



SEMI MANCAL P/PINO
Ø 50,00mm
SP501
(20 unidades)



**PINO DA BALANÇA
CARRETA TEMP**
Ø 50,00x235mm
SP681
SP681A - sem têmpera



**PINO DA BALANÇA
CARRETA TEMP**
Ø 50,00x235mm
C/MANCAL
SP668
SP668A - sem têmpera



**PINO DA BALANÇA
CARRETA TEMP**
Ø 50,00x225mm
SP680
SP680A - sem têmpera



**PINO DA BALANÇA
CARRETA TEMP**
Ø 50,00x215mm
SP682
SP682A - sem têmpera



**PINO DA BALANÇA
CARRETA TEMP**
Ø 50,00x215mm C/MANCAL
SP616
SP616A - sem têmpera

COMPATÍVEL COM LIBRELATO



**SUPORE DIANTEIRO
P/CARRETA ECO+**
SP857
**SUPORE GUIA SUSPENSÃO
DISTANCIADA ECO+**
SP878



**SUPORE CENTRAL
P/CARRETA ECO+**
SP858D - DIREITO
SP858E - ESQUERDO



**SUPORE CENTRAL
C/MANCAL**
SP888



**SUPORE TRASEIRO
P/CARRETA ECO+**
SP859



**BALANÇA ASA DELTA
SOLDADA C/BUCHA LUBFREE**
SP860 - ch. 8,00mm
SP860A - ch. 8,00mm - SEM BUCHA



**TENSOR REGULÁVEL
MONTADO**
SP862



**PONTEIRA DO TENSOR
REGULÁVEL**
SP564D - DIREITO
SP564E - ESQUERDO



**FUSO TENSOR
REGULÁVEL**
SP558 - 372mm
SP558B - 400mm



**SAPATA SUPERIOR
P/EIXO REDONDO**
SP871

COMPATÍVEL COM NOMA



**SUPOORTE DIANTEIRO
CARRETA MOD 2012**
SP839



**SUPOORTE CENTRAL
CARRETA MOD 2012**
SP840



**SUPOORTE CENTRAL
SUSPENSÃO DISTANCIADA
MOD 2012**
SP841



**SUPOORTE TRASEIRO
MOD 2012**
SP842
**SUPOORTE GUIA DIANTEIRO
SUSPENSÃO DISTANCIADA
MOD 2012**
SP843



**BALANÇA ASA DELTA
SOLDADA P/PINO Ø 61,30mm
P/CARRETA**
SP477 - ch. 8,00mm



**BALANÇA ASA DELTA
ESTAMPADA P/PINO Ø 61,30mm
P/CARRETA 2012**
SP535 - ch. 6,35mm



**SAPATA SUPERIOR
P/EIXO REDONDO
P/CARRETA 2012**
SP867



**SAPATA DESLIZANTE
DA ESFREGA**
SP695 - Corpo c/chapa 8,00mm
Esfrega c/chapa 12,70mm

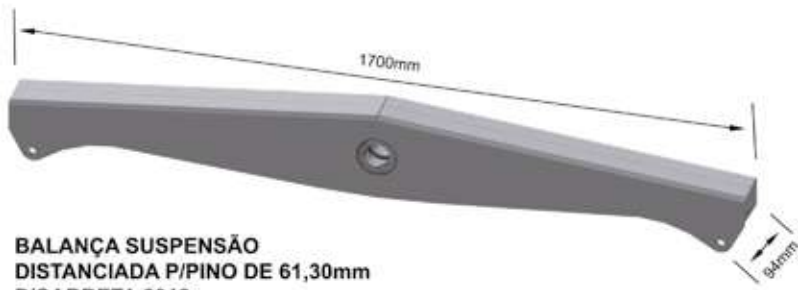

**BALANÇA SUSPENSÃO
DISTANCIADA P/PINO DE 61,30mm
P/CARRETA 2012**
SP662 - ch. 6,35mm



**SAPATA DESLIZANTE DA
ESFREGA MOD 2012**
SP661 - Corpo c/chapa 8,00mm
Esfrega c/chapa 12,70mm



**PONTEIRA DO TENSOR
FUNDIDA P/CARRETA**
SP868D - DIREITO
SP868E - ESQUERDO



**PINO DA BALANÇA CARRETA
TEMP Ø 61,30x190mm**
SP505
SP505A - sem têmpera



**PINO DA BALANÇA CARRETA
TEMP Ø 60,80x211mm**
SP506
SP506A - sem têmpera



**FUSO TENSOR
REGULÁVEL
P/CARRETA NOMA/
FACCHINI 480mm**
SP819



**BUCHA DO
TENSOR 70mm**
SP866



**BUCHA TEMPERADA
Ø INTERNO 61,30mm**
SP536 - (10 unidades)
**BUCHA TEMPERADA
Ø INTERNO 61,70mm**
SP533 - (10 unidades)

COMPATÍVEL COM FACCHINI



**SUPORE DIANTEIRO
CARRETA MOD 2016**
SP813



**SUPORE CENTRAL
CARRETA MOD 2016**
SP814



**SUPORE CENTRAL
CARRETA C/MANCAL**
SP889



**SUPORE CENTRAL
SUSPENSÃO DISTANCIADA
MOD 2016**
SP815



**SUPORE TRASEIRO
CARRETA MOD 2016**
SP816

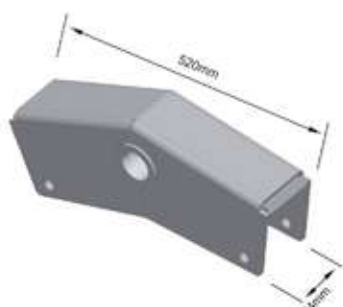

**BALANÇA ASA DELTA
ESTAMPADA P/PINO
Ø 50,00mm - 2008**
SP607 - ch. 8,00mm



**BALANÇA ASA DELTA
SOLDADA P/PINO
Ø 50,85mm - 2013**
SP651 - ch. 8,00mm



**BALANÇA ASA DELTA
SOLDADA C/BUCHA LUBFREE**
SP856 - ch. 8,00mm
SP856A - ch. 8,00mm - SEM BUCHA



**SAPATA DESLIZANTE
DA ESFREGA - 2013**
SP685 - Corpo c/chapa 8,00mm
Esfrega c/chapa 15,88mm



**SAPATA SUPERIOR
P/EIXO REDONDO**
SP869



**SAPATA INFERIOR
P/EIXO REDONDO**
SP870



**PINO DA BALANÇA
CARRETA TEMP Ø 50,85mm**
SP812
SP812A - sem têmpera



**BUCHA TEMPERADA
Ø INTERNO 51,30mm**
SP811
(10 unidades)

DIVERSOS

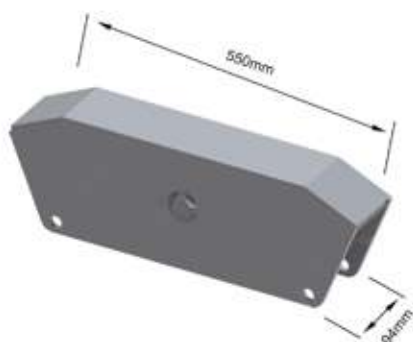

**BALANÇA ASA DELTA SOLDADA
P/PINO Ø 50,00mm TRUCK**
SP764 - ch. 8,00mm
**BALANÇA ASA DELTA SOLDADA
P/PINO Ø 60,00mm TRUCK**
SP849 - ch. 8,00mm



**BALANÇA ASA DELTA
SOLDADA C/BUCHA
LUBFREE CANAVIEIRA**
SP777 - ch. 8,00mm

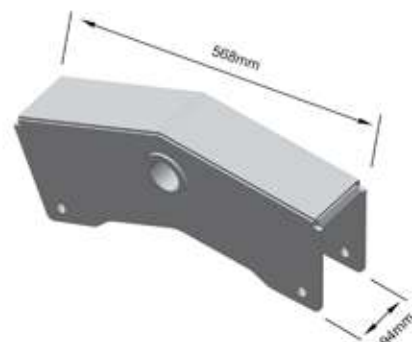

**BALANÇA ASA DELTA
SOLDADA P/PINO Ø 50,00mm
P/CARREGA TUDO**
SP610 - ch. 8,00mm

COMPATÍVEL COM MERCEDES-BENZ 1620/1622/1720



SUPORE DIANTEIRO TRUCK MB
SP619D - DIREITO
SP619E - ESQUERDO



SUPORE CENTRAL TRUCK MB
SP617



SUPORE CENTRAL TRUCK MB C/MANCAL SOLDADO
SP618



SUPORE TRASEIRO TRUCK MB
SP623D - DIREITO
SP623E - ESQUERDO



BALANÇA ASA DELTA SOLDADA P/PINO Ø 50,00mm TRUCK MB ANTIGO
SP637 - ch. 8,00mm



BALANÇA ASA DELTA SOLDADA P/PINO Ø 50,00mm TRUCK MB
SP510 - ch. 8,00mm



BALANÇA ASA DELTA ESTAMPADA P/PINO 50mm TRUCK MB ATEGO KLL
SP652 - ch. 8,00mm



TENSOR FIXO TRUCK MB 535mm
SP641



FUSO TENSOR REGULÁVEL 450mm TRUCK MB
SP644



SAPATA DESLIZANTE SUPORTE DIANTEIRO TRUCK MB
SP620



SAPATA DESLIZANTE SUPORTE TRASEIRO TRUCK MB
SP624



SAPATA SUPERIOR EIXO REDONDO TRUCK MB
SP622



SAPATA INFERIOR EIXO REDONDO TRUCK MB
SP642

COMPATÍVEL COM MERCEDES-BENZ ATEGO



SUPORE DIANTEIRO MB ATEGO
SP909D - DIREITO
SP909E - ESQUERDO



SUPORE CENTRAL C/MANCAL MB ATEGO
SP908



SUPORE TRASEIRO MB ATEGO
SP910D - DIREITO
SP910E - ESQUERDO



BALANCA ASA DELTA SOLDADA P/PINO Ø 50,00mm ATEGO 3030/2430
SP676 - ch. 8,00mm

COMPATÍVEL COM SCANIA 112/113/114/124 E VOLVO FH/NH/NL/EDC



LE

**SUPORE DIANTEIRO
TRUCK SC/VV**
SP625D - DIREITO
SP625E - ESQUERDO



**SUPORE CENTRAL
TRUCK SC/VV**
SP627



**SUPORE CENTRAL
TRUCK SC/VV C/MANCAL**
SP630



LE

**SUPORE TRASEIRO
TRUCK SC/VV**
SP626D - DIREITO
SP626E - ESQUERDO



**BALANÇA ASA DELTA
ESTAMPADA P/PINO Ø 50,00mm**
TRUCK SC/VV
SP629 - ch. 8,00mm



**SAPATA SUPERIOR
SUPORE DIANTEIRO
TRUCK SC**
SP628



**SAPATA SUPERIOR
DO EIXO DE TRAÇÃO
TRUCK VV**
SP645



**SAPATA P/EIXO
RETANGULAR**
SP544



**SAPATA DESLIZANTE
DA ESFREGA**
SP475 - Corpo c/chapa 9,50mm
SP475A - Corpo c/chapa 6,35mm
Esfrega c/chapa 12,70mm



**PINO DA BALANÇA
TRUCK/CAVALO TEMP**
Ø 50,00x180mm
SP494
SP494A - sem têmpera



**PINO CÔNICO P/MANCAL
C/PORCA 98mm**
SP503
(10 unidades)



**BUCHA MOLECULAR
TENSOR CARRETA**
SP557



**PONTEIRA DO TENSOR
FUNDIDA**
SP559D - DIREITO
SP559E - ESQUERDO



**FUSO TENSOR REGULÁVEL
P/CARRETA 315mm**
SP563



**TENSOR FIXO 480mm
CARRETA FUNDIDO**
SP560

COMPATÍVEL COM VOLKSWAGEN E FORD CARGO



LE

SUPORE DIANTEIRO TRUCK FORD/VW
SP634D - DIREITO
SP634E - ESQUERDO



SUPORE CENTRAL TRUCK FORD/VW
SP632



SUPORE CENTRAL TRUCK FORD/VW C/MANCAL
SP633



LE

SUPORE TRASEIRO TRUCK FORD/VW
SP631D - DIREITO
SP631E - ESQUERDA



SAPATA SUPERIOR TRACÃO EIXO RETANGULAR FORD/VW
SP636



SAPATA INFERIOR TRACÃO EIXO RETANGULAR FORD/VW
SP635



SAPATA P/EIXO REDONDO CARRETA
SP542



PINO CÔNICO P/MANCAL C/PORCA 98mm
SP503
 (10 unidades)



BALANÇA ASA DELTA SOLDADA P/PINO Ø 50,00mm TRUCK/VW/CARGO/VV/SC
SP538 - ch 8,00mm



BALANÇA ASA DELTA SOLDADA P/PINO Ø 50,00mm TRUCK VW TAMPA BAIXA
SP601 - ch. 8,00mm



PONTEIRA DO TENSOR FUNDIDA
SP559D - DIREITO
SP559E - ESQUERDO



PINO DA BALANÇA TRUCK/CAVALO TEMP Ø 50,00x190mm C/CAVA
SP539
SP539A - sem têmpera



PINO DA BALANÇA TRUCK/CAVALO TEMP Ø 50,00x190mm
SP488
SP488A - sem têmpera



TENSOR FIXO 480mm FUNDIDO
SP560



BUCHA MOLECULAR TENSOR CARRETA
SP557

CONJUNTOS DE SUSPENSÃO COMPATÍVEL COM RANDON



CÓDIGO	DESCRIÇÃO	QTD.
SP552	SUPORE SUSPENSÃO DIANTEIRO RD MOD 2000	1
SP473	SAPATA DESLIZANTE ESFREGA 5/8 RD	1
SP809	PARAFUSO SEX M16X150MM 8.8 C/PORCA	1

CONJUNTO SUSPENSÃO
SUPORE DIANTEIRO RD 2000

CJ003A



CÓDIGO	DESCRIÇÃO	QTD.
SP553	SUPORE SUSPENSÃO DIANTEIRO RD MOD 2008	1
SP475	SAPATA DESLIZANTE ESFREGA 1/2 RD	1
SP809	PARAFUSO SEX M16X150MM 8.8 C/PORCA	1

CONJUNTO SUSPENSÃO
SUPORE DIANTEIRO RD 2008

CJ003



CÓDIGO	DESCRIÇÃO	QTD.
SP614	SUPORE SUSPENSÃO CENTRAL MOD 2000 C/MANCAL	1
SP452	BALANCA ASA DELTA DOBRADA CH 5/16 PN 50MM	1
SP493	PINO BALANCA CAR 50X203MM	1
SP503	PINO CONICO P/MANCAL C/PORCA	1
SP807	PARAFUSO SEX M16X130MM 8.8 C/PORCA	2

CONJUNTO SUSPENSÃO
SUPORE CENTRAL RD 2000

CJ004A



CÓDIGO	DESCRIÇÃO	QTD.
SP555	SUPORE SUSPENSÃO CENTRAL RD MOD 2008	1
SP443A	BALANCA SOLDADA CH 5-16 LUBFREE C/BUCHA	1
SP656	PINO C/PORCA BALANCA RD/SUSPENSY	1
SP807	PARAFUSO SEX M16X130MM 8.8 C/PORCA	2

CONJUNTO SUSPENSÃO
SUPORE CENTRAL RD 2008

CJ004



CÓDIGO	DESCRIÇÃO	QTD.
SP556	SUPORE SUSPENSÃO TRASEIRO RD MOD 2000	1
SP473	SAPATA DESLIZANTE ESFREGA 5/8 RD	1
SP809	PARAFUSO SEX M16X150MM 8.8 C/PORCA	1

CONJUNTO SUSPENSÃO
SUPORE TRASEIRO RD

CJ002

CONJUNTOS DE SUSPENSÃO COMPATÍVEL COM GUERRA



CÓDIGO	DESCRIÇÃO	QTD.
SP549	SUPORE SUSPENSÃO DIANTEIRO MOD 2004	1
SP474	SAPATA DESLIZANTE ESFREGA 1/2	1
SP809	PARAFUSO SEX M16X150MM 8.8 C/PORCA	1

CONJUNTO SUSPENSÃO
SUPORE DIANTEIRO GE
CJ008



CÓDIGO	DESCRIÇÃO	QTD.
SP550	SUPORE SUSPENSÃO CENTRAL GE	1
SP487	BALANCA ASA DELTA SOLDADA CH 5/16 PN 50MM	1
SP616	PINO BALANCA CAR 50X215MM C/MANCAL	1
SP501	SEMI MANCAL P/PINO BALANCA DIAM 50MM	1
SP807	PARAFUSO SEX M16X130MM 8.8 C/PORCA	2
SP930	PARAFUSO SEX M16X50MM 8.8 C/PORCA	4

CONJUNTO SUSPENSÃO
SUPORE CENTRAL GE
CJ009



CÓDIGO	DESCRIÇÃO	QTD.
SP606	SUPORE SUSPENSÃO CENTRAL 1º BITREM GE	1
SP487	BALANCA ASA DELTA SOLD CH 5/16 PN 50MM GE	1
SP616	PINO BALANCA CAR 50X215MM C/MANCAL SOLD GE	1
SP501	SEMI MANCAL P/PINO BALANCA DIAM 50MM	1
SP807	PARAFUSO SEX M16X130MM 8.8 C/PORCA	2
SP930	PARAFUSO SEX M16X50MM 8.8 C/PORCA	4

CONJUNTO SUSPENSÃO SUPORE
CENTRAL 1º BITREM GE
CJ010



CÓDIGO	DESCRIÇÃO	QTD.
SP905D/E	SUPORE SUSPENSÃO CENTRAL CAR GE LUBFREE LE/LD	1
SP928	BALANCA ASA DELTA DOBR LUBFREE GE	1
SP656	PINO C/ PORCA BALANÇA LUBFREE	1
SP807	PARAFUSO SEX M16X130MM 8.8 C/PORCA	2

CONJUNTO SUSPENSÃO SUPORE
CENTRAL LUBFREE GE
CJ020



CÓDIGO	DESCRIÇÃO	QTD.
SP551	SUPORE SUSPENSÃO TRASEIRO GE	1
SP474	SAPATA DESLIZANTE ESFREGA 1/2 GE	1
SP809	PARAFUSO SEX M16X150MM 8.8 C/PORCA	1

CONJUNTO SUSPENSÃO
SUPORE TRASEIRO GE
CJ011

CONJUNTOS DE SUSPENSÃO COMPATÍVEL COM RANDON



CONJUNTO SUSPENSÃO
1 EIXO REDONDO 2000

CJ007

CONJUNTO SUSPENSÃO
1 EIXO RETANGULAR 2000

CJ007A

CÓDIGO	DESCRIÇÃO	QTD.			
SP552	SUPORE SUSPENSÃO DIANTEIRA CAR RD MOD 2000	2	SP559D	PONTEIRA TENSOR CAR RD 2000 FR FUNDIDO LD	1
SP556	SUPORE SUSPENSÃO TRASEIRA CARRETA RD MOD 2000	2	SP559E	PONTEIRA TENSOR CAR RD 2000 FR FUNDIDO LE	1
SP560	TENSOR FIXO 480MM RD 2002 FUNDIDO	1	SP563	FUSO TENSOR REGULAVEL CAR GE 313MM	1
SP557	BUCHA MOLECULAR TENSOR RANDON 2000	4	SP808	PARAFUSO SEX M24X140MM 8.8 C/PORCA	4
SP544/SP542	SAPATA P EIXO RETANGULAR/REDONDO RD	2	SP809	PARAFUSO SEX M16X150MM 8.8 C/PORCA	4
SP473	SAPATA DESLIZANTE ESFREGA 5-8 RD	4	SP810	PARAFUSO SEX M16X80MM 8.8 C/PORCA	2



CONJUNTO SUSPENSÃO
2 EIXOS REDONDO 2000

CJ006

CONJUNTO SUSPENSÃO
2 EIXOS RETANGULAR 2000

CJ006A

CÓDIGO	DESCRIÇÃO	QTD.			
SP552	SUPORE SUSPENSÃO DIANTEIRA CAR RD MOD 2000	2	SP557	BUCHA MOLECULAR TENSOR RD 2000	8
SP616	SUPORE SUSPENSÃO CENTRAL MOD 2000 C/MANCAL	2	SP544/SP542	SAPATA P EIXO RETANGULAR/REDONDO	4
SP556	SUPORE SUSPENSÃO TRASEIRA MOD 2000	2	SP559D	PONTEIRA TENSOR CAR RD 2000 LD	2
SP452	BALANÇA ASA DELTA DOBR CH 5-16" PN 50MM	2	SP559E	PONTEIRA TENSOR CAR RD 2000 LE	2
SP493	PINO BALANÇA CAR 50X203MM	2	SP563	FUSO TENSOR REGULAVEL 313MM	2
SP503	PINO CONICO P-MANCAL C/PORCA	2	SP807	PARAFUSO SEX M16X130MM 8.8 C/PORCA	4
SP473	SAPATA DESLIZANTE ESFREGA 5-8	4	SP808	PARAFUSO SEX M24X140MM 8.8 C/PORCA	8
SP560	TENSOR FIXO 480MM	2	SP809	PARAFUSO SEX M16X150MM 8.8 C/PORCA	4
			SP810	PARAFUSO SEX M16X80MM 8.8 C/PORCA	4

CONJUNTOS DE SUSPENSÃO COMPATÍVEL COM RANDON



CONJUNTO SUSPENSÃO
REBAIXADA 2 EIXOS
REDONDO 2000

CJ017

CONJUNTO SUSPENSÃO
REBAIXADA 2 EIXOS
RETANGULAR 2000

CJ017A

CÓDIGO	DESCRIÇÃO	QTD.
SP883	SUPORTE TRASEIRO SUSPENSÃO REBAIXADA	2
SP882	SUPORTE CENTRAL SUSPENSÃO REBAIXADA C-MANCAL	2
SP884	SUPORTE DIANTEIRO SUSPENSÃO REBAIXADA	2
SP638	BALANÇA ASA DELTA SOLD 5/16" PN 50MM CANAVIEIRA	2
SP493	PINO BALANCA CAR 50X203MM	2
SP503	PINO CÔNICO SUP CENTRAL	2
SP557	BUCHA MOLECULAR TENSOR RD	8
SP475	SAPATA DESLIZANTE ESFREGA 1/2 RD	2

SP869	SAPATA SUP P-EIXO REDONDO MOD FACCHINI	4
SP559D	PONTEIRA TENSOR CAR RD 2000 FR FUNDIDO LD	8
SP559E	PONTEIRA TENSOR CAR RD 2000 FR FUNDIDO LE	8
SP853A	TENSOR REGUL 480MM	4
SP807	PARAFUSO SEX M16X130MM 8.8 C/PORCA	4
SP808	PARAFUSO SEX M24X140MM 8.8 C/PORCA	8
SP809	PARAFUSO SEX M16X150MM 8.8 C/PORCA	4
SP810	PARAFUSO SEX M16X80MM 8.8 C/PORCA	8



CONJUNTO SUSPENSÃO
2 EIXOS REDONDO 2008

CJ018

CONJUNTO SUSPENSÃO
2 EIXOS RETANGULAR 2008

CJ018A

CÓDIGO	DESCRIÇÃO	QTD.
SP556	SUPORTE SUSPENSÃO TRASEIRO RD MOD 2000	2
SP473	SAPATA DESLIZANTE ESFREGA 5/8 RD	4
SP560	TENSOR FIXO 480MM RD	2
SP557	BUCHA MOLECULAR TENSOR RD	8
SP542/SP544	SAPATA P/EIXO REDONDO/QUADRADO RD	4
SP559D	PONTEIRA TENSOR CAR RD 2000 FUNDIDO LD	2
SP559E	PONTEIRA TENSOR CAR RD 2000 FUNDIDO LE	2

SP563	FUSO TENSOR REGULAVEL GE 313MM	2
SP553	SUPORTE SUSPENSÃO DIANTEIRA MOD 2008	2
SP555	SUPORTE SUSPENSÃO CENTRAL MOD 2008	2
SP443A	BALANCA ASA DELTA SOLD CH 5-16" PN 50MM RD	2
SP656	PINO COM PORCA BALANCA BUCHA MOLECULAR	2
SP807	PARAFUSO SEX M16X130MM 8.8 C/PORCA	8
SP809	PARAFUSO SEX M16X150MM 8.8 C/PORCA	4
SP810	PARAFUSO SEX M16X80MM 8.8 C/PORCA	4

CONJUNTOS DE SUSPENSÃO COMPATÍVEL COM RANDON



CONJUNTO SUSPENSÃO
3 EIXOS REDONDO RD 2008
CJ015

CONJUNTO SUSPENSÃO
3 EIXOS QUADRADO RD 2008
CJ015A

CÓDIGO	DESCRIÇÃO	QTD.			
SP556	SUPORTE SUSPENSÃO TRASEIRO RD	2	SP553	SUPORTE SUSPENSÃO DIANTEIRA MOD 2008	2
SP473	SAPATA DESLIZANTE ESFREGA 5/8	4	SP555	SUPORTE SUSPENSÃO CENTRAL MOD 2008	4
SP560	TENSOR FIXO 480MM RD	3	SP443A	BALANCA SOLDADA CH 5-16 LUBFREE 2011	4
SP557	BUCHA MOLECULAR TENSOR RD	12	SP656	PINO C/PORCA	4
SP542/SP544	SAPATA PARA EIXO REDONDO/QUADRADO RD	6	SP807	PARAFUSO SEX M16X130MM 8.8 C/PORCA	12
SP559D	PONTEIRA TENSOR CAR RD 2000 FUNDIDO LD	6	SP808	PARAFUSO SEX M24X140MM 8.8 C/PORCA	12
SP559E	PONTEIRA TENSOR CAR RD 2000 FUNDIDO LE	6	SP809	PARAFUSO SEX M16X150MM 8.8 C/PORCA	4
			SP810	PARAFUSO SEX M16X80MM 8.8 C/PORCA	6



CONJUNTO SUSPENSÃO
3 EIXOS REDONDO 2000
CJ013

CONJUNTO SUSPENSÃO
3 EIXOS QUADRADO 2000
CJ013A

CÓDIGO	DESCRIÇÃO	QTD.			
SP552	SUPORTE SUSPENSÃO DIANTEIRA CAR RD MOD 2000	2	SP557	BUCHA MOLECULAR TENSOR RD 2000	12
SP614	SUPORTE SUSPENSÃO CENTRAL MOD 2000 C/MANCAL	4	SP542/SP544	SAPATA PARA EIXO REDONDO/QUADRADO	6
SP556	SUPORTE SUSPENSÃO TRASEIRA MOD 2000	2	SP559D	PONTEIRA TENSOR CAR RD 2000 LD	6
SP452	BALANCA ASA DELTA DOBR CH 5-16" PN 50MM	4	SP559E	PONTEIRA TENSOR CAR RD 2000 LE	6
SP493	PINO BALANCA CAR 50X203MM	4	SP563	FUSO TENSOR REGULAVEL 313MM	3
SP503	PINO CONICO P-MANCAL C/PORCA	4	SP807	PARAFUSO SEX M16X130MM 8.8 C/PORCA	6
SP473	SAPATA DESLIZANTE ESFREGA 5/8	4	SP808	PARAFUSO SEX M24X140MM 8.8 C/PORCA	3
SP560	TENSOR FIXO 480MM	3	SP809	PARAFUSO SEX M16X150MM 8.8 C/PORCA	3
			SP810	PARAFUSO SEX M16X80MM 8.8 C/PORCA	3

CONJUNTOS DE SUSPENSÃO COMPATÍVEL COM RANDON

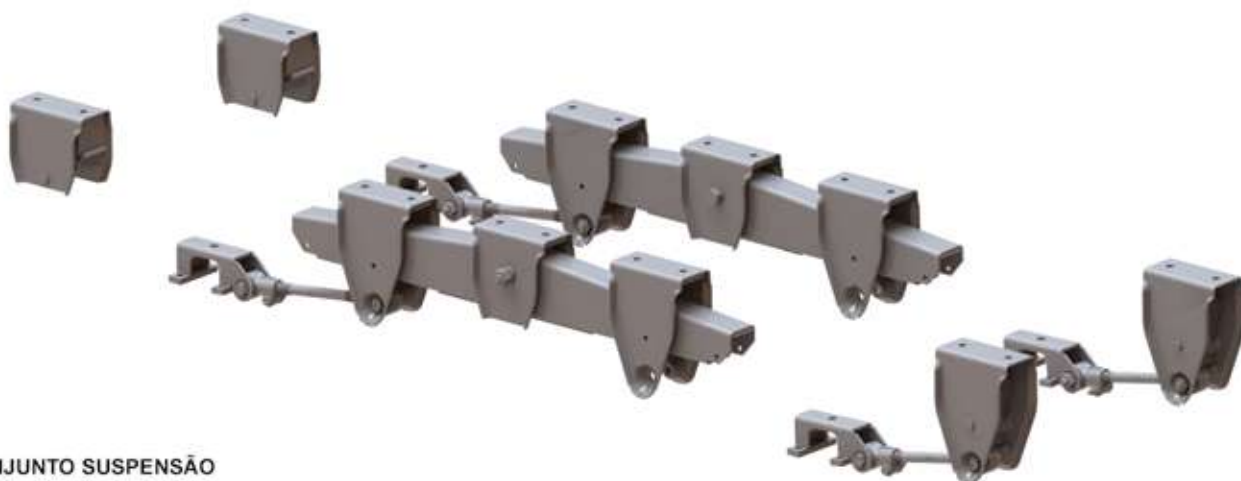

CONJUNTO SUSPENSÃO
DISTANCIADA LUBFREE
P/EIXO QUADRADO 2008
CJ016

CÓDIGO	DESCRIÇÃO	QTD.	SP544	SAPATA P/EIXO RETANGULAR	4
SP553	SUPORTE SUSPENSÃO DIANTEIRA MOD 2008	2	SP853A	TENSOR REGULAVEL 540MM	2
SP649	SUPORTE CENTRAL SUSPENSÃO DISTANCIADA	2	SP475	SAPATA DESLIZANTE ESFREGA 1-2	4
SP670	SUPORTE SUSPENSÃO GUIA CENTRAL MOD 2008	4	SP559E	PONTEIRA TENSOR RD MOD 2000 LE	4
SP556	SUPORTE SUSPENSÃO TRASEIRO MOD 2000	2	SP559D	PONTEIRA TENSOR RD MOD 2000 LD	4
SP640A	BALANÇA SOLDADA CH 5-16 C/BUCHA MOLECULAR	2	SP808	PARAFUSO SEX M24X140MM 8.8 C/PORCA	8
SP853A	TENSOR REGULAVEL 480MM	2	SP809	PARAFUSO SEX M16X150MM 8.8 C/PORCA	4
SP557	BUCHA MOLECULAR TENSOR	8	SP810	PARAFUSO SEX M16X80MM 8.8 C/PORCA	8

COMPATÍVEL COM GUERRA



CONJUNTO SUSPENSÃO
3 EIXOS REDONDO
CJ014

CONJUNTO SUSPENSÃO
3 EIXOS QUADRADO
CJ014A

CÓDIGO	DESCRIÇÃO	QTD.	SP548/SP547	SAPATA P/EIXO RETANGULAR/REDONDO	6
SP551	SUPORTE SUSPENSÃO TRASEIRO	2	SP549	SUPORTE SUSPENSÃO DIANTEIRO MOD 2004	2
SP474	SAPATA DESLIZANTE ESFREGA 1/2	4	SP564D	PONTEIRA FERRO FUNDIDA TENSOR LD	6
SP550	SUPORTE SUSPENSÃO CENTRAL	4	SP564E	PONTEIRA FERRO FUNDIDO TENSOR LE	6
SP487	BALANCA ASA DELTA SOLD CH 5-16 PN 50MM	4	SP563	FUSO TENSOR REGULAVEL 313MM	3
SP501	SEMI MANCAL P/PINO 50MM	4	SP807	PARAFUSO SEX M16X130MM 8.8 C/PORCA	8
SP562	BUCHA MOLECULAR TENSOR	12	SP809	PARAFUSO SEX M16X150MM 8.8 C/PORCA	4
SP546	TENSOR FIXO 435MM	3	SP810	PARAFUSO SEX M16X80MM 8.8 C/PORCA	28

CONJUNTOS DE SUSPENSÃO



CONJUNTO SUSPENSÃO
2 EIXOS REDONDO
TRUCK SCANIA

CJ012

CONJUNTO SUSPENSÃO
2 EIXOS RETANGULAR
TRUCK SCANIA

CJ012A

CÓDIGO	DESCRIÇÃO	QTD.
SP627	SUPORTE SUSPENSÃO CENTRAL	2
SP629	BALANÇA ASA DELTA DOBR CH 5-16 PN 50MM	2
SP494	PINO BALANÇA TRUCK 50X177MM	2
SP503	PINO CONICO 98MM SUPORTE CENTRAL C/ROSCA	2
SP557	BUCHA MOLECULAR TENSOR	8
SP559D	PONTEIRA TENSOR FUNDIDO LD	2
SP559E	PONTEIRA TENSOR FUNDIDO LE	2
SP563	FUSO TENSOR REGULAVEL 313MM	2
SP544/542	SAPATA PARA EIXO REDONDO/RETANGULAR	2
SP625D	SUPORTE SUSPENSÃO DIANTEIRO LD	1

SP625E	SUPORTE SUSPENSÃO DIANTEIRO LE	1
SP475	SAPATA DESLIZANTE ESFREGA 1/2	4
SP628	SAPATA DESLIZANTE SUPORTE DIANTEIRO	1
SP626D	SUPORTE SUSPENSÃO TRASEIRO LD	1
SP626E	SUPORTE SUSPENSÃO TRASEIRO LE	1
SP502	MANCAL SUPORTE CENTRAL P/PINO 50MM	2
SP560	TENSOR FIXO 480MM	2
SP807	PARAFUSO SEX M16X130MM 8.8 C/PORCA	4
SP808	PARAFUSO SEX M24X140MM 8.8 C/PORCA	8
SP810	PARAFUSO SEX M16X80MM 8.8 C/PORCA	4



CONJUNTO SUSPENSÃO 2 EIXOS
REDONDO CARGO/VOLKS
LINHA PESADA

CJ005

CÓDIGO	DESCRIÇÃO	QTD.
SP560	TENSOR FIXO 480MM	2
SP557	BUCHA MOLECULAR TENSOR	6
SP633	SUPORTE SUSPENSÃO CENTRAL VW	2
SP544/542	SAPATA PARA EIXO REDONDO/RETANGULAR	2
SP538	BALANÇA SOLD 5-16" PN 50MM	2
SP539	PINO BALANÇA TRUCK 50X188MM	2
SP503	PINO CONICO P/MANCAL C/PORCA	2
SP631D	SUPORTE SUSPENSÃO TRASEIRO LD	1
SP631E	SUPORTE SUSPENSÃO TRASEIRO LE	1

SP475	SAPATA DESLIZANTE ESFREGA 1-2	4
SP636	SAPATA TRACÇÃO EIXO RETANGULAR	2
SP634D	SUPORTE SUSPENSÃO DIANTEIRO LD	1
SP634E	SUPORTE SUSPENSÃO DIANTEIRO LE	1
SP809	PARAFUSO SEX M16X150MM C/PORCA	4
SP559D	PONTEIRA FERRO FUNDIDO TENSOR LD	2
SP559E	PONTEIRA FERRO FUNDIDO TENSOR LE	2
SP563	FUSO TENSOR REGULAVEL 313MM	2
SP808	PARAFUSO SEX M24X140MM 8.8 C/PORCA	8
SP810	PARAFUSO SEX M16X80MM 8.8 C/PORCA	4

LINHA **SUSPENSÃO**

SUSPENSOR CAR/BT CHASSI ATÉ 980mm SP380

(FERRAGENS, GRAMPOS,
LIMITADOR E BOLSA)

SUSPENSOR CAR/BT CHASSI ATÉ 980mm SP380B (SOMENTE FERRAGENS)



SUSPENSOR CAR/BT CHASSI ATÉ 980mm C/KIT DE AR SP380C

(FERRAGENS, GRAMPOS, LIMITADOR, BOLSA E KIT AR)

SUSPENSOR CAR/BT CHASSI ATÉ 980mm S/GRAMPOS E S/LIMITADOR SP380D

(FERRAGENS E BOLSA)

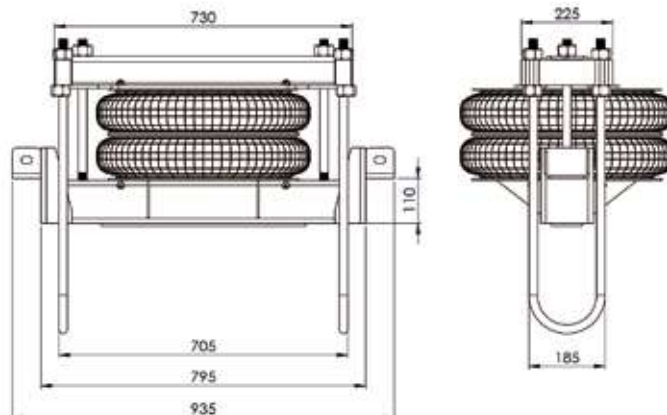

1. LIMITADOR 7/8"x400mm SP380.4

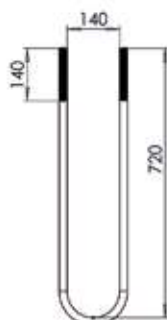

2. GRAMPO 7/8"x140x720mm UNF MOD C SP380A

2. GRAMPO 7/8"x140x720mm UNF MOD D SP531B

3. MOLA PNEUMÁTICA 7.14 SP393

4. SUPORTE SUPERIOR SP380.2



5. SUPORTE INFERIOR SP380.1



SUSPENSOR CAR/BT CHASSI ATÉ 980mm GUERRA SP382

(FERRAGENS, GRAMPOS E BOLSA)

SUSPENSOR CAR/BT CHASSI ATÉ 980mm GUERRA SP382B (SOMENTE FERRAGENS)

SUSPENSOR CAR/BT CHASSI ATÉ 980mm GUERRA C/KIT DE AR SP382C

(FERRAGENS, GRAMPOS, BOLSA E KIT AR)

SUSPENSOR CAR/BT CHASSI ATÉ 980mm GUERRA S/GRAMPOS SP382D

(FERRAGENS E BOLSA)

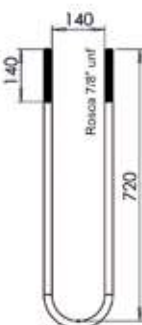
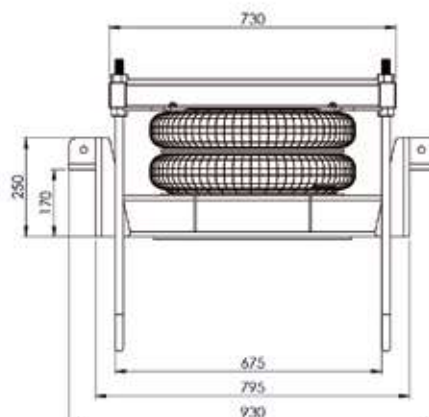

1. GRAMPO SUSPENSOR 7/8"x140x720mm UNF MOD C SP380A

1. GRAMPO SUSPENSOR 7/8"x140x720mm UNF MOD D SP531B

2. MOLA PNEUMÁTICA 7.14 SP393

3. SUPORTE FIXAÇÃO CHASSI SP382.3



4. SUPORTE SUPERIOR SP382.2



5. SUPORTE INFERIOR SP382.1



LINHA SUSPENSÃO

SUSPENSOR CARRETA/BITREM CHASSI ATÉ 980mm LINHA R/LIBRELATO

SP381
(FERRAGENS, GRAMPOS E BOLSA)

SUSPENSOR CARRETA/BITREM CHASSI ATÉ 980mm LINHA R/LIBRELATO

SP381B
(SOMENTE FERRAGENS)

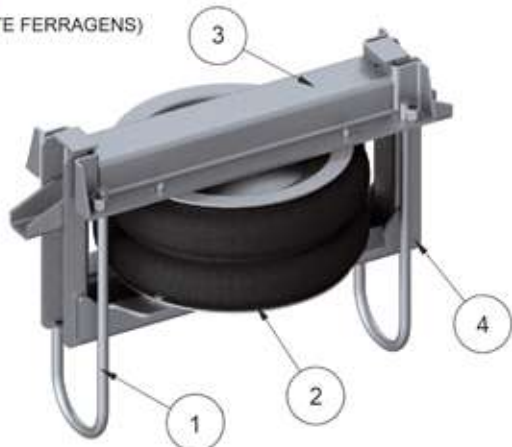

SUSPENSOR CARRETA/BITREM CHASSI ATÉ 980mm LINHA R/LIBRELATO C/KIT DE AR

SP381C
(FERRAGENS, GRAMPOS, BOLSA E KIT AR)

SUSPENSOR CARRETA/BITREM CHASSI ATÉ 980mm LINHA R/LIBRELATO S/GRAMPOS

SP381D
(FERRAGENS E BOLSA)

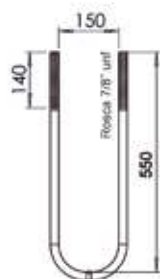
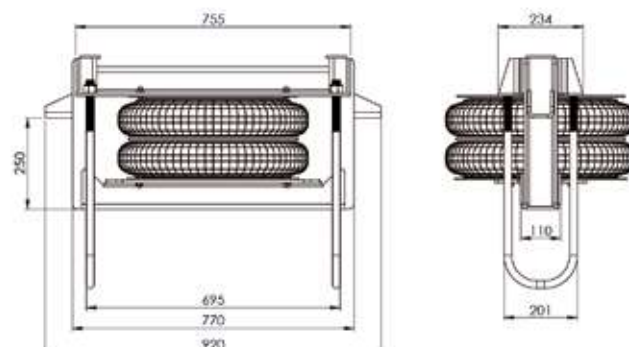

1. GRAMPO 7/8"x150x550mm UNF MOD C
SP381A

1. GRAMPO 7/8"x150x550mm UNF MOD D
SP381E

2. MOLA PNEUMÁTICA 7.14
SP393

3. SUPORTE SUPERIOR
SP381.2



4. SUPORTE INFERIOR
SP381.1



SUSPENSOR CAR/BT CHASSI ATE 1050mm

SP873
(FERRAGENS, GRAMPOS E BOLSA)

SUSPENSOR CAR/BT CHASSI ATE 1050mm

SP851B
(SOMENTE FERRAGENS)

SUSPENSOR CAR/BT CHASSI ATE 1050mm S/GRAMPOS

SP873C
(FERRAGENS E BOLSA)

SUSPENSOR CAR/BT CHASSI ATE 1050mm C/KIT DE AR

SP873D
(FERRAGENS, GRAMPOS, BOLSA E KIT AR)

SUSPENSOR CAR/BT CHASSI ATE 1050mm BOLSA 7.14 ST4001

SP851
(FERRAGENS, GRAMPOS E BOLSA)

SUSPENSOR CAR/BT CHASSI ATE 1050mm BOLSA 7.14 ST4001 S/GRAMPOS

SP851C
(FERRAGENS E BOLSA)

SUSPENSOR CAR/BT CHASSI ATE 1050mm BOLSA 7.14 ST4001 C/KIT DE AR

SP851D
(FERRAGENS, GRAMPOS, BOLSA E KIT AR)

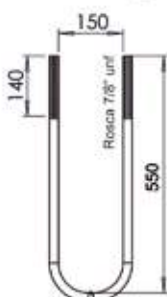
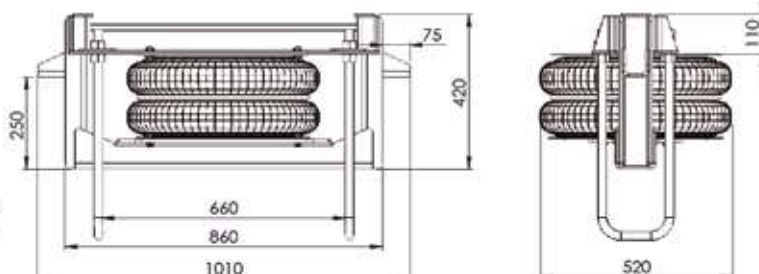

1. GRAMPO 7/8"x150x550mm UNF MOD C
SP381A

1. GRAMPO 7/8"x150x550mm UNF MOD D
SP381E

2. MOLA PNEUMÁTICA 7.14
SP393

2. MOLA PNEUMÁTICA 7.14 ST4001
SP393B

3. BASE SUP SUSPENSOR CAR/BT 1050mm
SP851.1



4. BASE INF SUSPENSOR CAR/BT 1050mm
SP851.2



SUSPENSOR CARRETA/BITREM MOD UNIVERSAL

SP466
(FERRAGENS, GRAMPOS,
LIMITADOR E BOLSA)



SUSPENSOR CARRETA/BITREM MOD UNIVERSAL

SP466B
(SOMENTE FERRAGENS)

SUSPENSOR CAR/BT MOD UNIVERSAL C/KIT DE AR

SP466C
(FERRAGENS, GRAMPOS,
LIMITADOR, BOLSA E KIT AR)

SUSPENSOR CAR/BT MOD UNIVERSAL S/GRAMPOS E S/LIMITADOR

SP466D
(FERRAGENS E BOLSA)

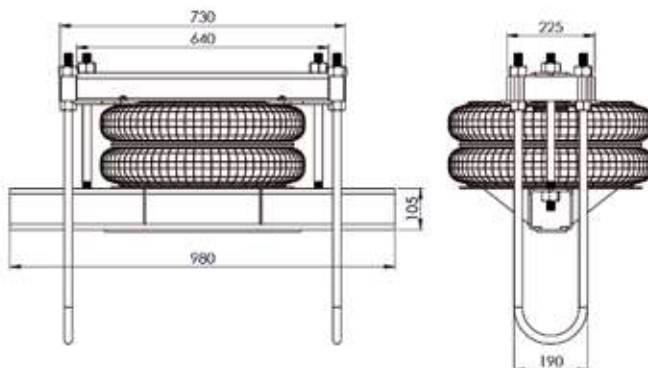

1. LIMITADOR 7/8"x400mm SP380.4



2. GRAMPO SUSPENSOR 7/8"x140x720mm UNF SP380A - MOD C SP531B - MOD D

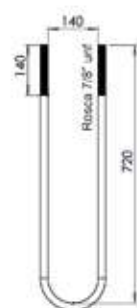

3. MOLA PNEUMÁTICA 7.14 SP393

4. SUPORTE FIXAÇÃO CHASSI SP466.1



OBS.: QUANDO FOR
NECESSÁRIO REBAIXAR
O SUSPENSOR, USAR
SP466.1

5. SUPORTE SUPERIOR SP380.2



6. SUPORTE INFERIOR SP466.3



SUSPENSOR TRUCK RETO MOD UNIVERSAL

SP653
(FERRAGENS, GRAMPOS,
LIMITADOR E BOLSA)

SUSPENSOR TRUCK RETO MOD UNIVERSAL

SP653B
(SOMENTE FERRAGENS)

SUSPENSOR TRUCK RETO MOD UNIVERSAL C/KIT DE AR

SP653C
(FERRAGENS, GRAMPOS,
LIMITADOR, BOLSA E KIT AR)

SUSPENSOR TRUCK RETO MOD UNIVERSAL S/GRAMPOS E S/LIMITADOR

SP653D
(FERRAGENS E BOLSA)

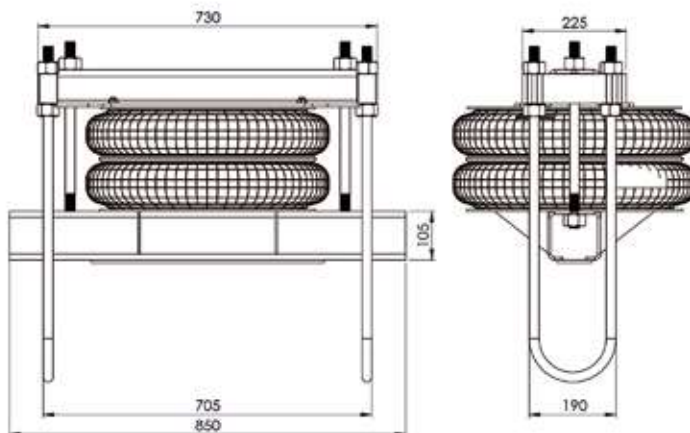

1. LIMITADOR 7/8"x400mm SP380.4

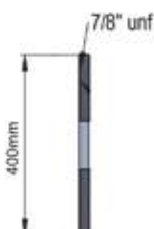

2. GRAMPO SUSPENSOR 7/8"x140x720mm UNF MOD C SP380A

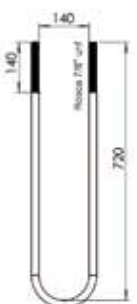

2. GRAMPO SUSPENSOR 7/8"x140x720mm UNF MOD D SP531B

3. MOLA PNEUMÁTICA 7.14 SP393

4. SUPORTE SUPERIOR SP380.2



5. SUPORTE INFERIOR SP653.2



SUSPENSOR BASCULANTE CHASSI ATÉ 1040mm NOMA SP613
(FERRAGENS, GRAMPOS, LIMITADOR E BOLSA)



SUSPENSOR BASCULANTE CHASSI ATÉ 1040mm NOMA SP613B
(SOMENTE FERRAGENS)

SUSPENSOR BASCULANTE CHASSI ATÉ 1040mm NOMA C/KIT DE AR SP613C
(FERRAGENS, GRAMPOS, LIMITADOR, BOLSA E KIT AR)

SUSPENSOR BASCULANTE CHASSI ATÉ 1040mm NOMA S/GRAMPOS E S/LIMITADOR SP613D
(FERRAGENS E BOLSA)

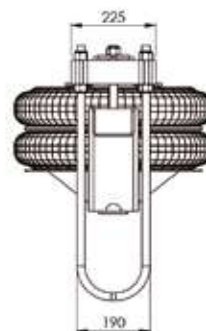
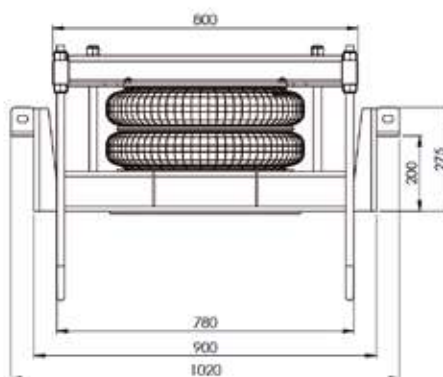

1. LIMITADOR 7/8"x400mm SP380.4

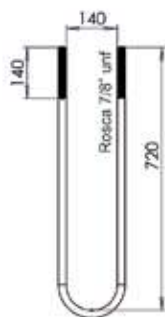

2. GRAMPO SUSPENSOR 7/8"x140x720mm UNF MOD C SP380A

2. GRAMPO SUSPENSOR 7/8"x140x720mm UNF MOD D SP531B

3. MOLA PNEUMÁTICA 7.14 SP393

4. SUPORTE SUPERIOR SP613.1



5. SUPORTE INFERIOR SP613.2



SUSPENSOR BASCULANTE CHASSI ATÉ 1040mm SP531 - EIXO REDONDO SP531C - EIXO QUADRADO
(FERRAGENS, GRAMPOS, LIMITADOR E BOLSA)

SUSPENSOR BASCULANTE CHASSI ATÉ 1040mm SP531D
(SOMENTE FERRAGENS)

SUSPENSOR BASCULANTE CHASSI ATÉ 1040mm C/KIT DE AR SP531E
(FERRAGENS, GRAMPOS, LIMITADOR, BOLSA E KIT AR)

SUSPENSOR BASCULANTE CHASSI ATÉ 1040mm S/GRAMPOS E S/LIMITADOR SP531F
(FERRAGENS E BOLSA)

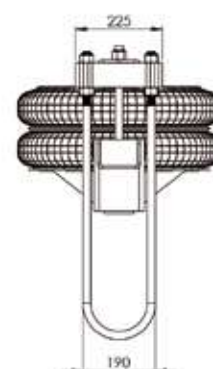
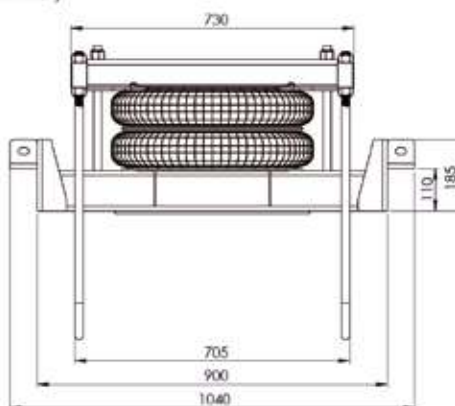

1. LIMITADOR 400mm SP380.4

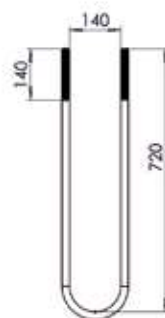

2. GRAMPO SUSPENSOR 7/8"x140x720mm UNF SP380A - MOD C SP531B - MOD D

3. MOLA PNEUMÁTICA 7.14 SP393

4. SUPORTE SUPERIOR SP380.2



5. SUPORTE INFERIOR SP531.1



SUSPENSOR BASCULANTE/TANQUE CHASSI ATÉ 1040mm MOD FACCHINI
SP845
 (FERRAGENS, GRAMPOS, LIMITADOR E BOLSA)



SUSPENSOR BASCULANTE/TANQUE CHASSI ATÉ 1040mm MOD FACCHINI
SP845B
 (SOMENTE FERRAGENS)

SUSPENSOR BASCULANTE/TANQUE CHASSI ATÉ 1040mm MOD FACCHINI C/KIT DE AR
SP845C
 (FERRAGENS, GRAMPOS, LIMITADOR, BOLSA E KIT AR)

SUSPENSOR BASCULANTE/TANQUE CHASSI ATÉ 1040mm MOD FACCHINI S/GRAMPOS
SP845D
 (FERRAGENS E BOLSA)

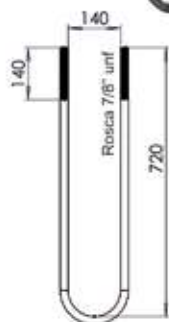
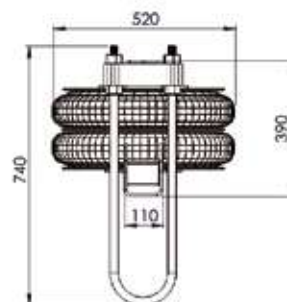
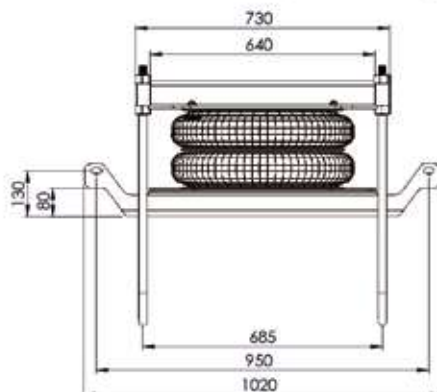

2. GRAMPO SUSPENSOR 7/8"x140x720mm UNF MOD C
SP380A

2. GRAMPO SUSPENSOR 7/8"x140x720mm UNF MOD D
SP531B

3. MOLA PNEUMÁTICA 7.14
SP393

4. SUPORTE SUPERIOR
SP845.1



5. SUPORTE INFERIOR
SP845.2



SUSPENSOR BASCULANTE CHASSI ATÉ 1040mm
SP929
 (FERRAGENS, GRAMPOS, LIMITADOR E BOLSA)

SUSPENSOR BASCULANTE CHASSI ATÉ 1040mm
SP929B
 (SOMENTE FERRAGENS)

SUSPENSOR BASCULANTE CHASSI ATÉ 1040mm C/KIT DE AR
SP929C
 (FERRAGENS, GRAMPOS, LIMITADOR, BOLSA E KIT AR)

SUSPENSOR BASCULANTE CHASSI ATÉ 1040mm S/GRAMPOS E S/LIMITADOR
SP929D
 (FERRAGENS E BOLSA)

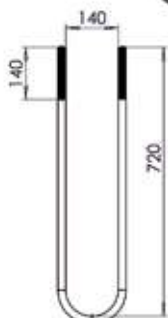
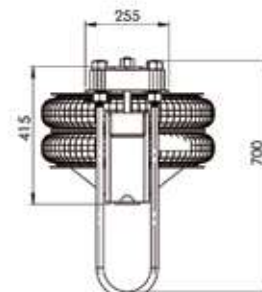
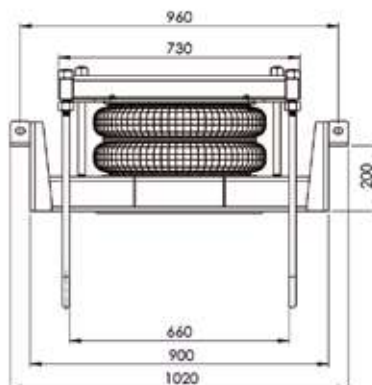

2. GRAMPO SUSPENSOR 7/8"x140x720mm UNF MOD C
SP380A

2. GRAMPO SUSPENSOR 7/8"x140x720mm UNF MOD D
SP531B

3. MOLA PNEUMÁTICA 7.14
SP393

1. LIMITADOR 400mm
SP380.4

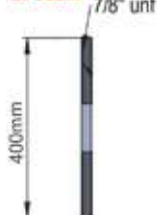

4. SUPORTE SUPERIOR
SP380.2



5. SUPORTE INFERIOR
SP613.2



SUSPENSOR CAR FLORESTAL CHASSI ATÉ 1040mm

SP728
(FERRAGENS, GRAMPOS E BOLSA)



SUSPENSOR CAR FLORESTAL CHASSI ATÉ 1040mm

SP728B
(SOMENTE FERRAGENS)

SUSPENSOR CAR FLORESTAL CHASSI ATÉ 1040mm C/KIT DE AR

SP728C
(FERRAGENS, GRAMPOS, BOLSA E KIT AR)

SUSPENSOR CAR FLORESTAL CHASSI ATÉ 1040mm S/GRAMPOS

SP728D
(FERRAGENS E BOLSA)

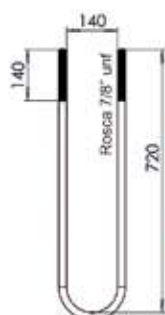
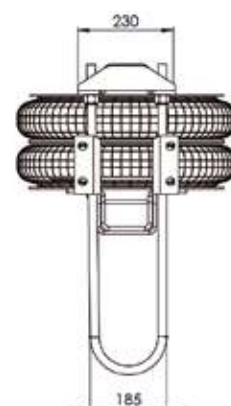
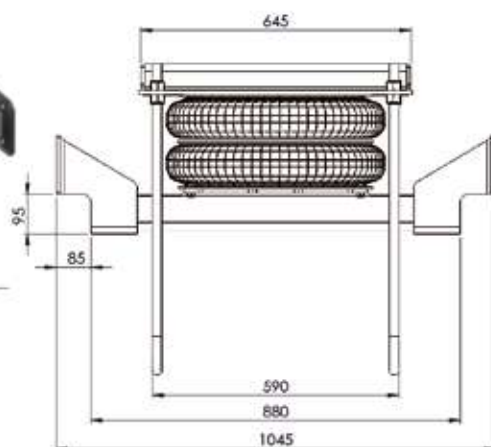

1. GRAMPO SUSPENSOR
7/8"x140x720mm
UNF MOD C
SP380A

1. GRAMPO SUSPENSOR
7/8"x140x720mm
UNF MOD D
SP531B

2. MOLA PNEUMÁTICA 7.14
SP393

3. SUPORTE SUPERIOR
SP728.1



4. SUPORTE INFERIOR
SP728.2



5. CHAPA FIXAÇÃO CHASSI
SP728.3

SUSPENSOR BITREM CHASSI ATÉ 980mm 3º EIXO PESADO

SP603
(FERRAGENS, GRAMPOS E BOLSA)

SUSPENSOR BITREM CHASSI ATÉ 980mm 3º EIXO PESADO

SP603B
(SOMENTE FERRAGENS)

SUSPENSOR BITREM CHASSI ATÉ 980mm 3º EIXO PESADO C/KIT DE AR

SP603C
(FERRAGENS, GRAMPOS, BOLSA E KIT AR)

SUSPENSOR BITREM CHASSI ATÉ 980mm 3º EIXO PESADO S/GRAMPOS

SP603D
(FERRAGENS E BOLSA)

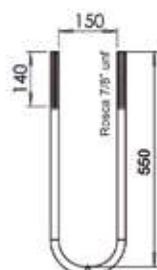
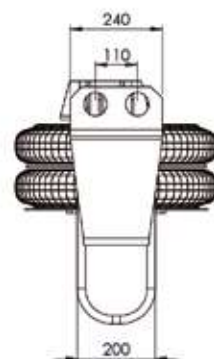
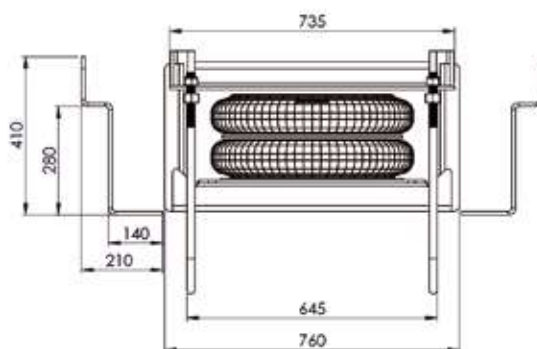
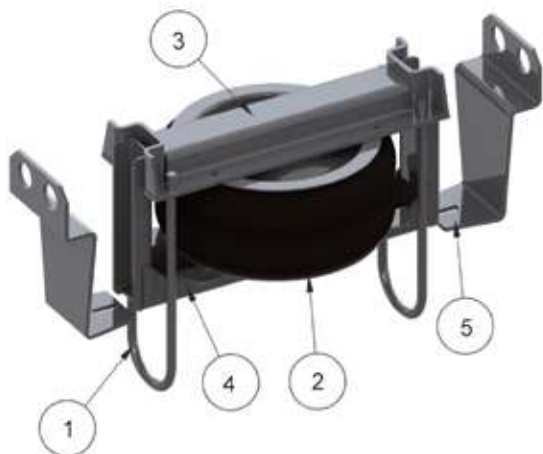

1. GRAMPO SUSPENSOR
7/8"x150x550mm UNF MOD C
SP381A

1. GRAMPO SUSPENSOR
7/8"x150x550mm UNF MOD D
SP381E

2. MOLA PNEUMÁTICA 7.14
SP393

3. SUPORTE SUPERIOR
SP603.1



4. SUPORTE INFERIOR
SP603.2



5. SUPORTE FIXAÇÃO CHASSI
SP603.3



SUSPENSOR TRUCK MOD UNIVERSAL

SP479
(FERRAGENS, GRAMPOS E BOLSA)

SUSPENSOR TRUCK MOD UNIVERSAL

SP479B
(SOMENTE FERRAGENS)

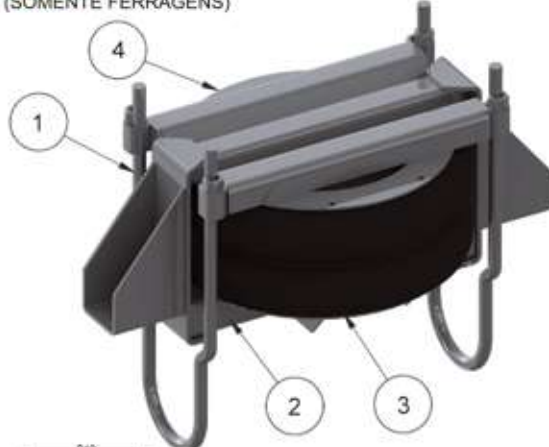

SUSPENSOR TRUCK MOD UNIVERSAL C/KIT DE AR

SP479C
(FERRAGENS, GRAMPOS, BOLSA E KIT AR)

SUSPENSOR TRUCK MOD UNIVERSAL S/GRAMPOS

SP479D
(FERRAGENS E BOLSA)

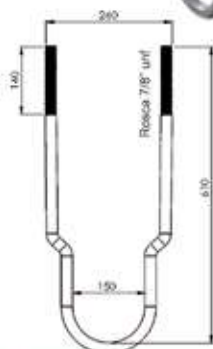
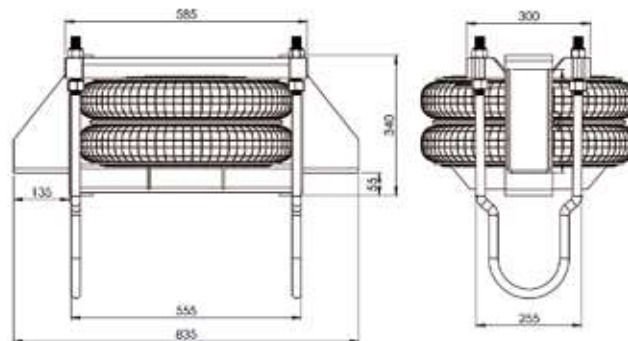

1. GRAMPO SUSPENSOR
7/8"x150x610mm UNF
CARA DE BOI MOD C
SP392A

1. GRAMPO SUSPENSOR
7/8"x150x610mm UNF
CARA DE BOI MOD D
SP392E

2. MOLA PNEUMÁTICA 6.13
SP393A

3. SUPORTE SUPERIOR
SP479.2



4. SUPORTE INFERIOR
SP479.1



SUSPENSOR 2º EIXO DIRECIONAL

SP480
(FERRAGENS, GRAMPOS E BOLSA)

SUSPENSOR 2º EIXO DIRECIONAL

SP480B
(SOMENTE FERRAGENS)

SUSPENSOR 2º EIXO DIRECIONAL C/KIT DE AR

SP480C
(FERRAGENS, GRAMPOS, BOLSA E KIT AR)

SUSPENSOR 2º EIXO DIRECIONAL S/GRAMPOS

SP480F
(FERRAGENS E BOLSA)

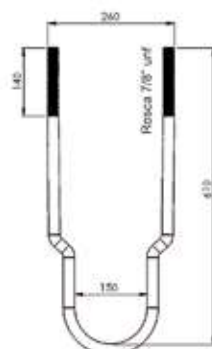
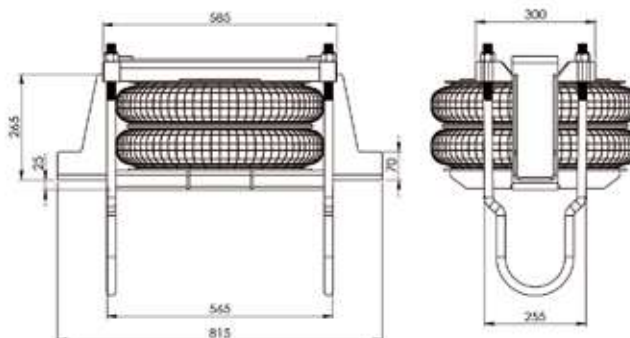

1. GRAMPO SUSPENSOR
7/8"x150x610mm UNF
CARA DE BOI MOD C
SP392A

1. GRAMPO SUSPENSOR
7/8"x150x610mm UNF
CARA DE BOI MOD D
SP392E

2. MOLA PNEUMÁTICA 6.13
SP393A

3. SUPORTE SUPERIOR
SP480.2



4. SUPORTE INFERIOR
SP480.1



5. SUPORTE FIXAÇÃO
SP480D - DIREITO
SP480E - ESQUERDO



SUSPENSOR TRUCK MB 1620
SP643
(FERRAGENS, GRAMPOS E BOLSA)

SUSPENSOR TRUCK MB 1620
SP643B
(SOMENTE FERRAGENS)

SUSPENSOR TRUCK MB 1620
C/KIT DE AR
SP643C
(FERRAGENS, GRAMPOS,
BOLSA E KIT AR)

SUSPENSOR TRUCK MB 1620
S/GRAMPOS
SP643D
(FERRAGENS E BOLSA)

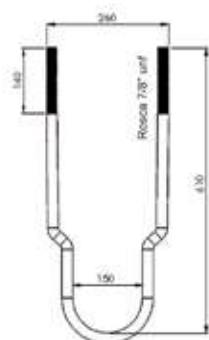
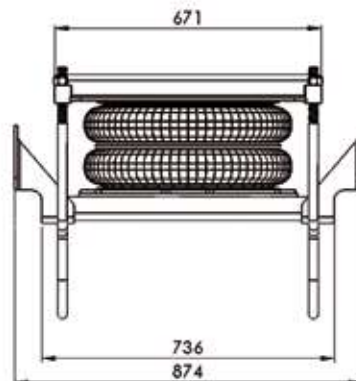
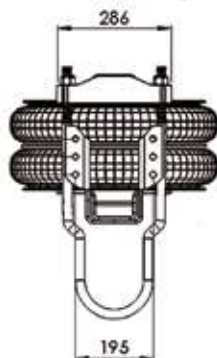

- 1. GRAMPO SUSPENSOR 7/8"x150x610mm UNF CARA DE BOI MOD C **SP392A**
- 1. GRAMPO SUSPENSOR 7/8"x150x610mm UNF CARA DE BOI MOD D **SP392E**
- 2. MOLA PNEUMÁTICA 6.13 **SP393A**

3. SUPORTE SUPERIOR
SP643.1



4. SUPORTE INFERIOR
SP643.2



5. SUPORTE FIXAÇÃO CHASSI
SP643.3 - 3 FUROS
SP643.4 - 2 FUROS

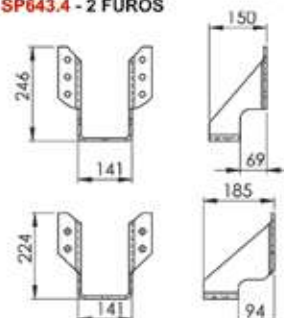

SUSPENSOR TRUCK CHASSI ATÉ 880mm
PARAFUSADO LEVE
SP397
(FERRAGENS, GRAMPOS E BOLSA)

SUSPENSOR TRUCK CHASSI ATÉ 880mm
PARAFUSADO LEVE C/KIT DE AR
SP397C
(FERRAGENS, GRAMPOS, BOLSA E KIT AR)

SUSPENSOR TRUCK CHASSI ATÉ 880mm
PARAFUSADO LEVE S/GRAMPOS
SP397D
(FERRAGENS E BOLSA)

SUSPENSOR TRUCK CHASSI ATÉ 880mm
PARAFUSADO LEVE
SP397B
(SOMENTE FERRAGENS)

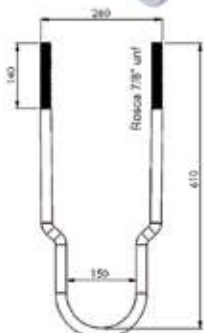
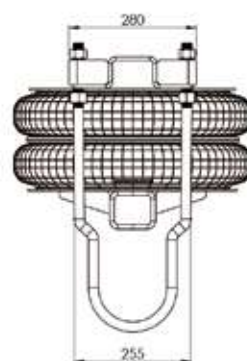
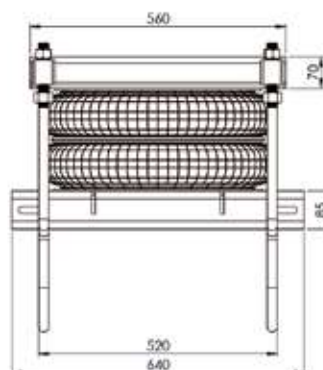
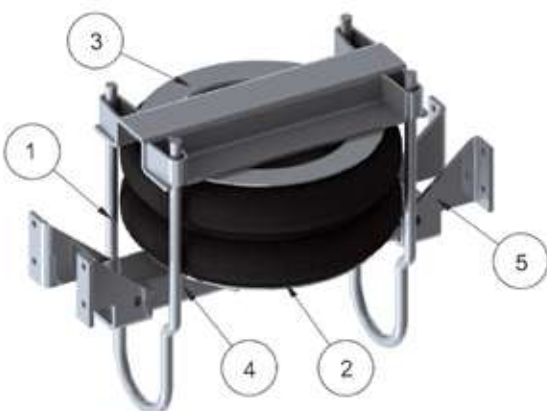

- 1. GRAMPO SUSPENSOR 7/8"x150x610mm UNF CARA DE BOI MOD C **SP392A**
- 1. GRAMPO SUSPENSOR 7/8"x150x610mm UNF CARA DE BOI MOD D **SP392E**
- 2. MOLA PNEUMÁTICA 6.13 **SP393A**

3. SUPORTE SUPERIOR
SP397.1



4. SUPORTE INFERIOR
SP397.2



5. SUPORTE FIXAÇÃO CHASSI
SP397.3



LINHA SUSPENSÃO

SUSPENSOR TRUCK
MB 1513/1313
SP885
 (FERRAGENS, GRAMPOS E BOLSA)

SUSPENSOR TRUCK
MB 1513/1313
SP885B
 (SOMENTE FERRAGENS)

SUSPENSOR TRUCK
MB 1513/1313 C/KIT DE AR
SP885C
 (FERRAGENS, GRAMPOS,
 BOLSA E KIT AR)

SUSPENSOR TRUCK
MB 1513/1313 S/GRAMPOS
SP885D
 (FERRAGENS E BOLSA)

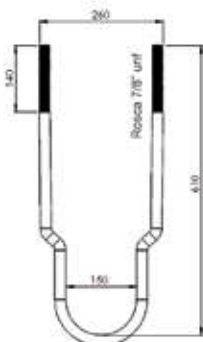
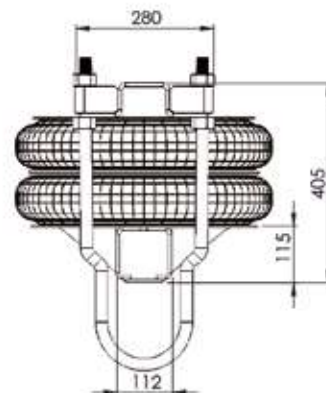
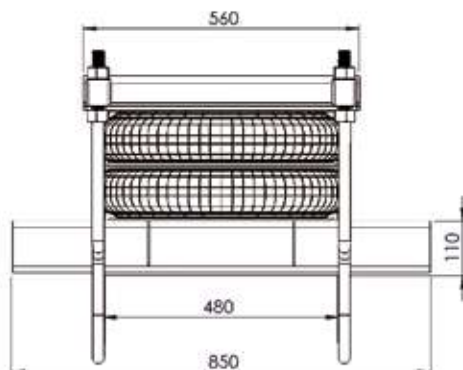
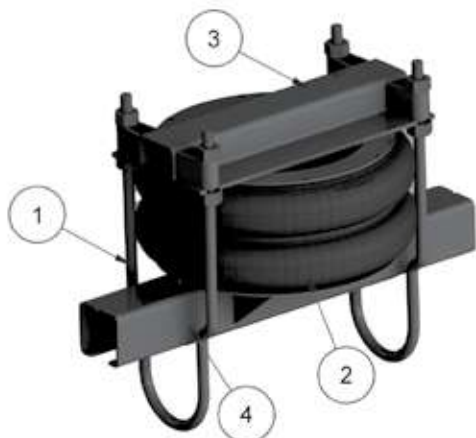

1. GRAMPO SUSPENSOR
 7/8"x150x610mm UNF
 CARA DE BOI MOD C
SP392A

1. GRAMPO SUSPENSOR
 7/8"x150x610mm UNF
 CARA DE BOI MOD D
SP392E

2. MOLA PNEUMÁTICA 6.13
SP393A

3. SUPORTE SUPERIOR
SP397.1



4. SUPORTE INFERIOR
SP885.1



5. SUPORTE FIXAÇÃO
CHASSI
SP397.3



SUSPENSOR TRUCK MB 1513/1313
REBAIXADO C/BOLSA 7.14
SP886
 (FERRAGENS, GRAMPOS E BOLSA)

SUSPENSOR TRUCK MB 1513/1313
REBAIXADO C/BOLSA 7.14 C/KIT DE AR
SP886C
 (FERRAGENS, GRAMPOS, BOLSA E KIT AR)

SUSPENSOR TRUCK MB 1513/1313
REBAIXADO C/BOLSA 7.14 S/GRAMPOS
SP886D
 (FERRAGENS E BOLSA)

SUSPENSOR TRUCK MB 1513/1313
REBAIXADO C/BOLSA 7.14
SP886B
 (SOMENTE FERRAGENS)

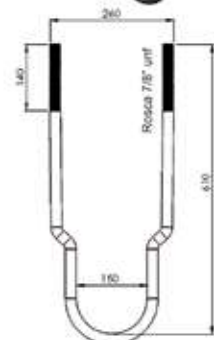
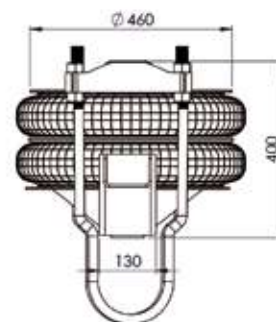
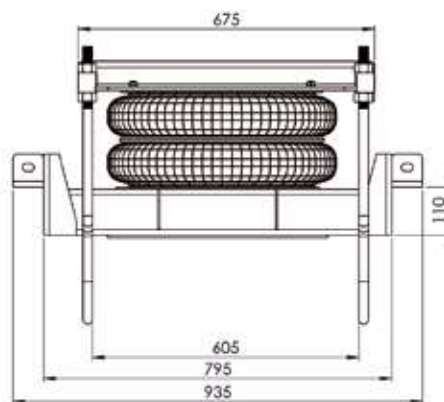

1. GRAMPO SUSPENSOR
 7/8"x150x610mm UNF
 CARA DE BOI MOD C
SP392A

1. GRAMPO SUSPENSOR
 7/8"x150x610mm UNF
 CARA DE BOI MOD D
SP392E

2. MOLA PNEUMÁTICA 7.14
SP393

3. SUPORTE SUPERIOR
SP643.1



4. SUPORTE INFERIOR
SP380.1



SUSPENSOR TRUCK CHASSI 760MM LEVE SP729

(FERRAGENS, GRAMPOS E BOLSA)

SUSPENSOR TRUCK CHASSI 760MM LEVE SP729B

(SOMENTE FERRAGENS)

SUSPENSOR TRUCK CHASSI 760MM LEVE C/KIT DE AR SP729C

(FERRAGENS, GRAMPOS,
BOLSA E KIT AR)

SUSPENSOR TRUCK CHASSI 760MM LEVE S/GRAMPOS SP729D

(FERRAGENS E BOLSA)

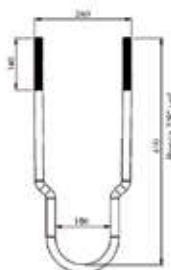
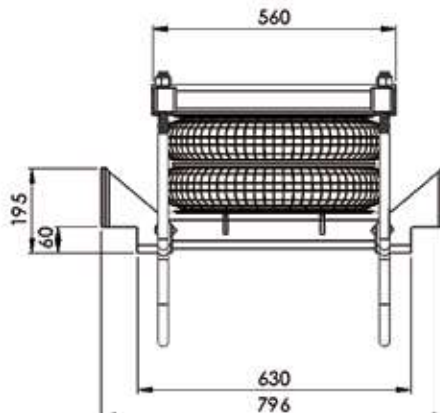
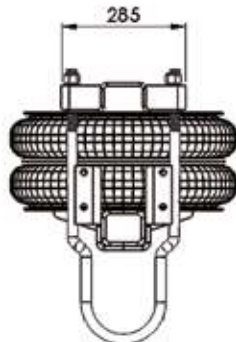

1. GRAMPO SUSPENSOR
7/8"x150x610mm UNF
CARA DE BOI MOD C
SP392A

1. GRAMPO SUSPENSOR
7/8"x150x610mm UNF
CARA DE BOI MOD D
SP392E

2. MOLA PNEUMÁTICA 6.13
SP393A

3. SUPORTE SUPERIOR
SP397.1



4. SUPORTE INFERIOR
SP729.2



5. SUPORTE
FIXAÇÃO
CHASSI
SP397.3



SUSPENSOR INVERTIDO SILO CHASSI ATE 980mm SP890

(FERRAGENS, GRAMPOS E BOLSA)

SUSPENSOR INVERTIDO SILO CHASSI ATE 980mm SP890B

(SOMENTE FERRAGENS)

SUSPENSOR INVERTIDO SILO CHASSI ATE 980mm C/KIT DE AR SP890C

(FERRAGENS, GRAMPOS,
LIMITADOR, BOLSA E KIT AR)

SUSPENSOR INVERTIDO SILO CHASSI ATE 980mm S/GRAMPOS E S/LIMITADOR SP890D

(FERRAGENS E BOLSA)

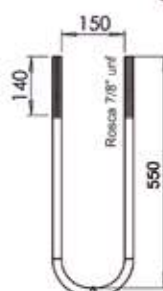
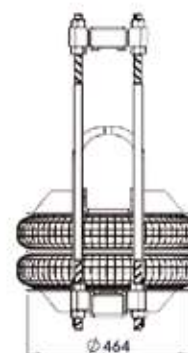
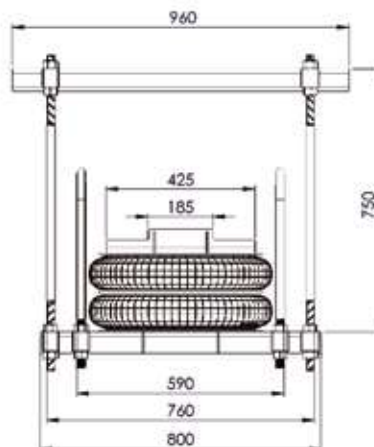

1. GRAMPO SUSPENSOR
7/8"x150x550mm UNF MOD C
SP381A

1. GRAMPO SUSPENSOR
7/8"x150x550mm UNF MOD D
SP381E

2. MOLA PNEUMÁTICA
7.14 - ST4001
SP393B

3. LIMITADOR 900mm
SP890.4



5. SUPORTE SUPERIOR
SP890.2



4. SUPORTE INFERIOR
SP890.1



6. SUPORTE BASE DE
FIXAÇÃO CHASSI
SP890.3





**BASE SUPERIOR SUSPENSOR
CAR/BT C/DISCO**
SP380.3



**BASE SUPERIOR SUSPENSOR
CAR/BT C/DISCO**
SP381.3



**BASE INFERIOR SUSPENSOR CHASSI
ATÉ 980mm RD LN R/LB C/DISCO**
SP381.4



**BASE SUPERIOR SUSPENSOR
BASC/TANQUE NM C/DISCO**
SP613.3



**BASE SUPERIOR SUSPENSOR
TRUCK MB 1620 C/DISCO**
SP643.5



**BASE INFERIOR SUSPENSOR
TRUCK MB 1620 C/DISCO**
SP643.6



**BASE INFERIOR SUSPENSOR
FLORESTAL CH 1040mm C/DISCO**
SP728.4



**BASE INFERIOR SUSPENSOR FLORESTAL
CHASSI ATÉ 1040mm C/DISCO**
SP728.5



**BASE SUPERIOR SUSPENSOR CH
980mm REFORÇADO C/DISCO**
SP603.6



**BASE INFERIOR SUSPENSOR
CH 980mm REFORÇADO C/DISCO**
SP603.7



**BASE INFERIOR SUSPENSOR FLORESTAL
CHASSI ATÉ 1050mm C/DISCO**
SP851.3



**BASE SUPERIOR SUSPENSOR
CAR/BT CH 1050mm C/DISCO**
SP851.4



**BASE INFERIOR SUSPENSOR
BASC/TANQUE CH 1040mm
MOD FACCHINI C/DISCO**
SP845.2



ESFREGA DA BALANÇA
CHAPA 12,70mm
SP676 – 82x170mm
SP676A – 82x157mm
 (10 unidades)



ESFREGA DA BALANÇA
CHAPA 12,70mm
SP677 – 90x170mm
SP677A – 90x200mm
SP677B – 90x220mm
 (10 unidades)



ESFREGA DA BALANÇA
CHAPA 12,70mm
SP935 – 92x160mm
SP935A – 92x130mm
 (10 unidades)



BUCHA TEMPERADA
Ø INTERNO 50,20x117mm
SP660
 (10 unidades)



ARRUELA TRAVA PARAFUSO
DA BALANÇA RD/GE/LB
SP931
 (10 unidades)



ARRUELA FIXAÇÃO
PARAFUSO DA BALANÇA
RD/GE/LB
SP932
 (10 unidades)



ARRUELA TRAVA PARAFUSO
DA BALANÇA NOMA 2012
SP933
 (10 unidades)



ARRUELA FIXAÇÃO
PARAFUSO DA BALANÇA
NOMA 2012
SP934
 (10 unidades)



LIMITADOR 7/8"x400mm
SP380.4

LIMITADOR 7/8"x450mm
SP466.4



DISCO INFERIOR MOLA
PNEUMÁTICA 7.14 - Ø 472mm
SP380.1.2

DISCO INFERIOR MOLA
PNEUMÁTICA 6.13 - Ø 458mm
SP397.3.3



DISCO SUPERIOR MOLA
PNEUMÁTICA 7.14 - Ø 472mm
SP380.2.1

DISCO SUPERIOR MOLA
PNEUMÁTICA 6.13 - Ø 458mm
SP397.1.3



MOLA PNEUMÁTICA DO
SUSPENSOR GRANDE 7.14
SP393

MOLA PNEUMÁTICA DO
SUSPENSOR PEQUENO 6.13
SP393A

MOLA PNEUMÁTICA DO
SUSPENSOR GRANDE 7.14
ST4001
SP393B

KIT SUSPENSOR DE AR CARRETA

SP450 – mangueira de 6,00mm
SP450A – mangueira de 8,00mm

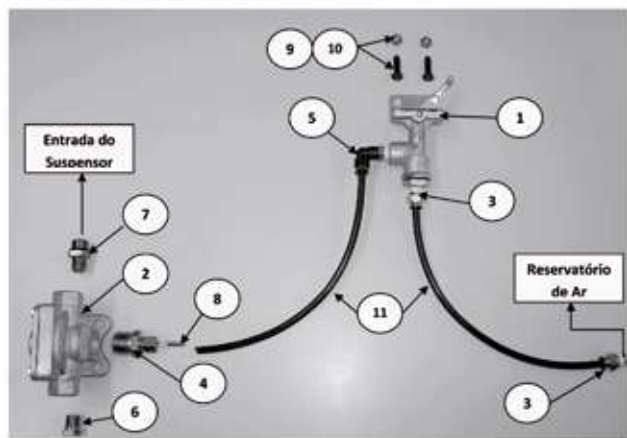

KIT SUSPENSOR DE AR TRUCK

SP451

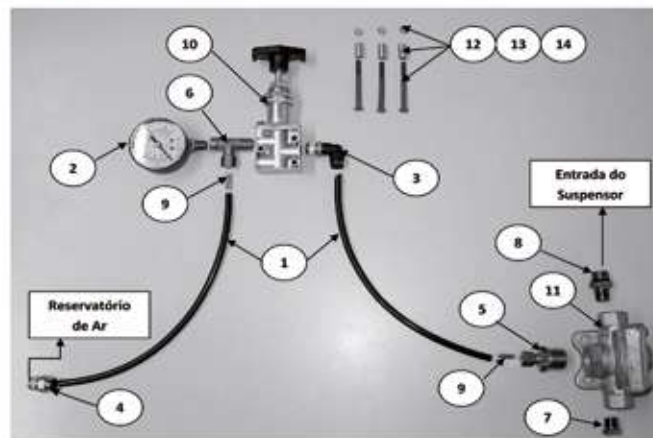



**RESERVATÓRIO AR CARRETA
FREIOS ABS S/FLANGE**

**SP921 - 75L
SP920 - 117L**



**RESERVATÓRIO AR CARRETA
FREIOS ABS**

**SP166A - 75L
SP167A - 117L**



**RESERVATÓRIO AR CARRETA
FREIOS ABS C/CONEXÃO**

**SP922 - 75L
SP923 - 117L**



**RESERVATÓRIO DE AR CARRETA
FREIOS ABS C/CONEXÃO
E ENTRE FUROS SUPORTE 140mm**

**SP925 - 75L
SP924 - 117L**



**RESERVATÓRIO AR CARRETA
FREIOS ABS SUPORTE FIXAÇÃO
ENTRE FUROS 140mm**

**SP927 - 75L
SP926 - 117L**



**RESERVATÓRIO AR CARRETA
FREIOS ABS C/SUPORTE LATERAL**

**SP904 - 75L
SP903 - 117L**



**RESERVATÓRIO AR CARRETA
FREIOS ABS S/SUPORTE**

**SP919 - 75L
SP918 - 117L**



**RESERVATÓRIO AR
CARRETA FREIOS ABS 40 L**

SP673A



**CINTA PARA FIXAÇÃO
RESERVATÓRIO AR 75L**

SP916

**CINTA PARA FIXAÇÃO
RESERVATÓRIO AR 117L**

SP917



**CONEXÃO P/
RESERVATÓRIO
DE AR ANTIGO**

SP726

LINHA CAIXAS

A METAL C PRODUZ CAIXAS DE FERRAMENTAS EM MEDIDAS ESPECIAIS CONFORME NECESSIDADE DO CLIENTE, ALÉM DE OFERECER A OPÇÃO DE ESTAMPAR O LOGOTIPO NAS PORTAS DAS CAIXAS.

*PADRÃO DE MEDIDA: ALTURA x COMPRIMENTO x PROFUNDIDADE



CAIXA DE FERRAMENTAS
600x535x600mm
CX005 - 26,000kg

CAIXA DE FERRAMENTAS
500x600x600mm
CX016 - 25,700kg

CAIXA DE FERRAMENTAS
600x600x600mm
CX010 - 29,000kg

CAIXA DE FERRAMENTAS
500x500x500mm
CX014 - 21,000kg



CAIXA DE FERRAMENTAS
600x900x600mm
CX012 - 38,500kg

CAIXA DE FERRAMENTAS
600x1000x600mm
CX006B - 42,000kg

CAIXA DE FERRAMENTAS
600x1100x600mm
CX008B - 45,000kg

CAIXA DE FERRAMENTAS
600x1140x600mm
CX009B - 47,000kg



CAIXA DE FERRAMENTAS P/
CEGONHEIRA 500x700x250mm
CX001 - 18,500kg

CAIXA DE FERRAMENTAS P/
CEGONHEIRA 500x1000x300mm
CX002 - 27,320kg



CAIXA DE FERRAMENTAS P/
FURGÃO 300x500x500mm
CX003 - 16,000kg



CAIXA DE FERRAMENTAS
P/BASCULANTE
300x500x300mm
CX013 - 9,200kg



CAIXA DE FERRAMENTAS P/FURGÃO
300x500x500mm C/FECHADURA PLÁSTICA
CX003P - 16,000kg

CAIXA DE FERRAMENTAS
600x535x600mm C/FECHADURA PLÁSTICA
CX005P - 26,000kg

CAIXA DE FERRAMENTAS
500x600x600mm C/FECHADURA PLÁSTICA
CX016P - 25,700kg

CAIXA DE FERRAMENTAS
600x600x600mm C/FECHADURA PLÁSTICA
CX010P - 29,000kg

CAIXA DE FERRAMENTAS
500x500x500mm C/FECHADURA PLÁSTICA
CX014P - 21,000kg

CAIXA DE FERRAMENTAS
600x900x600mm C/FECHADURA PLÁSTICA
CX012P - 38,500kg

CAIXA DE FERRAMENTAS
600x1000x600mm C/FECHADURA PLÁSTICA
CX006P - 42,000kg

CAIXA DE FERRAMENTAS
600x1100x600mm C/FECHADURA PLÁSTICA
CX008P - 45,000kg

CAIXA DE FERRAMENTAS
600x1140x600mm C/FECHADURA PLÁSTICA
CX009P - 47,000kg



FECHADURA
PLÁSTICA
P/CAIXA
SP478

PARA-CHOQUE MÓVEL MONTADO PBT 4,60 A 10,00 TON

HOMOLOGADO PELO INMETRO CONFORME Nº 7960721 - CATERG.



**PARA-CHOQUE MÓVEL MONTADO
PBT 4,60 a 10,00 TON**
SP820 - 39,000kg



**COLUNA FIXAÇÃO DO
PARA-CHOQUE 295mm**
SP820.2 - ch. 4,25mm - 2,650kg



**COLUNA MÓVEL DO
PARA-CHOQUE 372mm**
SP820.3 - ch. 4,25mm - 3,870kg



LÂMINA PARA-CHOQUE 2100mm
SP820.1 - ch. 4,25mm - 17,850kg



REFORÇO LATERAL 524mm
SP820.5 - ch. 4,25mm - 2,600kg



REFORÇO CENTRAL 645mm
SP820.4 - ch. 4,25mm - 3,575kg



**PINO DE
ARTICULAÇÃO**
Ø 15,88x138mm
SP767.7 - 0,770kg



**MÃO FRANCESA
FIXAÇÃO COLUNA**
SP820.6 - 0,385kg



MOLA TENSORA 580mm
SP168.9 - 0,830kg

PARA-CHOQUE MÓVEL MONTADO PBT 10,00 A 23,50 TON

HOMOLOGADO PELO INMETRO CONFORME Nº 7950621 - CATERG.



**PARA-CHOQUE MÓVEL MONTADO
PBT 10,00 a 23,50 TON**
SP767 - ch. 3,00mm ST700 - 36,000kg



**COLUNA FIXAÇÃO DO
PARA-CHOQUE 370mm**
SP767.2 - ch. 3,00mm ST700 - 2,600kg



**COLUNA MÓVEL
PARA-CHOQUE 470mm**
SP767.5 - ch. 3,00mm ST700 - 3,760kg



LÂMINA PARA-CHOQUE 2400mm
SP767.1 - ch. 3,00mm ST700 - 13,500kg



REFORÇO LATERAL 674mm
SP767.4 - ch. 3,00mm ST700 - 2,490kg



REFORÇO CENTRAL 695mm
SP767.3 - ch. 3,00mm ST700 - 2,819kg



**PINO DE
ARTICULAÇÃO**
Ø 25,40x208mm
SP768.6 - 0,750kg



**MÃO FRANCESA
FIXAÇÃO COLUNA**
SP767.6 - ch. 3,00mm ST700 - 0,390kg



MOLA TENSORA 580mm
SP168.9 - 0,830kg

PARA-CHOQUE MÓVEL MONTADO PBT ACIMA DE 23,50 TON

HOMOLOGADO PELO INMETRO CONFORME Nº 7940421 - CATERG.



Imagem ilustrativa

PARA-CHOQUE MÓVEL MONTADO PBT ACIMA DE 23,50 TON
SP768 - 57,000kg



COLUNA FIXAÇÃO DO PARA-CHOQUE 320mm
SP768.2 - ch. 4,00mm ST700 - 3,000kg

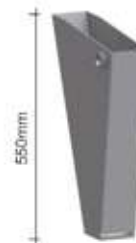

COLUNA MÓVEL MONTADA ALTURA 550mm
SP768.5 - ch. 4,00mm ST700 - 9,960kg



LÂMINA PARA-CHOQUE 2400mm
SP768.1 - ch. 4,00mm ST700 - 14,820kg



REFORÇO LATERAL 537mm
SP768.4 - ch. 4,00mm ST700 - 3,900kg



REFORÇO CENTRAL 850mm
SP768.3 - ch. 4,00mm ST700 - 5,330kg



PINO DE ARTICULAÇÃO
Ø 25,40x208mm
SP768.6 - 0,750kg



MOLA TENSORA 580mm
SP168.9 - 0,830kg

SAIBA MAIS SOBRE NOSSOS PARA-CHOQUES

Almejando cada vez mais **proporcionar soluções** aos seus clientes, a Metal C desenvolve seus produtos buscando **redução de custos e pesos** e preservando a qualidade e resistência dos mesmos.

Acompanhando as evoluções e novas tecnologias em materiais, a Metal C passou a produzir **dois de seus modelos de para-choques em chapas de alta resistência**.

As chapas de alta resistência contêm em sua composição química o Titânio e o Nióbio. Juntamente com os demais componentes do aço, elas resultam em **maior resistência** e se tornam **superiores ao aço comum**, quando comparados diretamente. Dessa maneira, podemos unir **resistência e qualidade**, oferecendo um produto mais leve, com **melhor custo-benefício**.

Todos os modelos de para-choques da Metal C são homologados **conforme as normas do INMETRO**, oferecendo a segurança necessária ao seu implemento.

LINHA PROTETOR LATERAL

HOMOLOGADO PELO INMETRO CONFORME RESOLUÇÃO DO CONTRAN 953/22

PROTETOR LATERAL MÓVEL COM FIXAÇÃO NO CHASSI, PARA CARRETA, TRUCK E TANQUE.



CONJUNTO PROTETOR LATERAL FIXAÇÃO CHASSI

SP731 - perfil "u" comp. 500mm
SP731A - perfil "u" comp. 650mm
SP731B - perfil "u" comp. 850mm



MÃO FRANCESA P/PERFIL "U" 500mm

SP701 - comp. 695mm

MÃO FRANCESA P/PERFIL "U" 650mm

SP701A - comp. 740mm

MÃO FRANCESA P/PERFIL "U" 850mm

SP701B - comp. 860mm

SUPORE FIXAÇÃO CHASSI TUBO 40x60x700mm
SP700



PERFIL "U" FRONTAL FIXAÇÃO TRAVESSAS

SP702 - comp. 500mm

SP702A - comp. 650mm

SP702B - comp. 850mm

PROTETOR LATERAL MÓVEL COM FIXAÇÃO NA TRAVESSA PARA CARROCERIA.



CONJUNTO PROTETOR LATERAL FIXAÇÃO TRAVESSA

SP817 - perfil "u" comp. 500mm
SP817A - perfil "u" comp. 650mm
SP817B - perfil "u" comp. 850mm



SUPORE DE FIXAÇÃO TRAVESSA 350mm
SP703



MÃO FRANCESA P/PERFIL "U" 500mm

SP704 - comp. 485mm

MÃO FRANCESA P/PERFIL "U" 650mm

SP704A - comp. 600mm

MÃO FRANCESA P/PERFIL "U" 850mm

SP704B - comp. 785mm



PERFIL "U" FRONTAL FIXAÇÃO TRAVESSAS

SP702 - comp. 500mm

SP702A - comp. 650mm

SP702B - comp. 850mm

PROTETOR LATERAL MÓVEL COM FIXAÇÃO NO CHASSI POR MORDENTES.



CONJUNTO PROTETOR LATERAL FIXAÇÃO CHASSI

SP818



SUPORE FIXAÇÃO DA TRAVESSA 500mm
SP818.2



MORDENTE FIXAÇÃO PERFIL/CHASSI
SP818.3



PERFIL DE FIXAÇÃO PROTETOR LATERAL
SP818.1

LINHA PROTETOR LATERAL

A METAL C DESENVOLVE SUPORTES DE PROTETOR LATERAL PARA MONTADORAS DE IMPLEMENTOS RODOVIÁRIOS CONFORME NECESSIDADE.



TRAVESSA PROTETOR LATERAL METAL 40x100x3000mm
SP1113 - ch. 2,00mm



KIT TRAVA PROTETOR LATERAL
SP875
(10 unidades)



PONTEIRA PLÁSTICA CURVADA 30x100mm
SP1118P - 500mm



PONTEIRA PLÁSTICA CURVADA 40x100mm
SP1177 - 40x100mm
SP1177A - 30x100mm
(10 unidades)



PONTEIRA PLÁSTICA CURVADA - 40x100mm
SP1124D - LADO DIREITO
SP1124E - LADO ESQUERDO

PONTEIRA PLÁSTICA CURVADA - 30x100mm
SP1124A.D - LADO DIREITO
SP1124A.E - LADO ESQUERDO

APLICAÇÕES



SP817

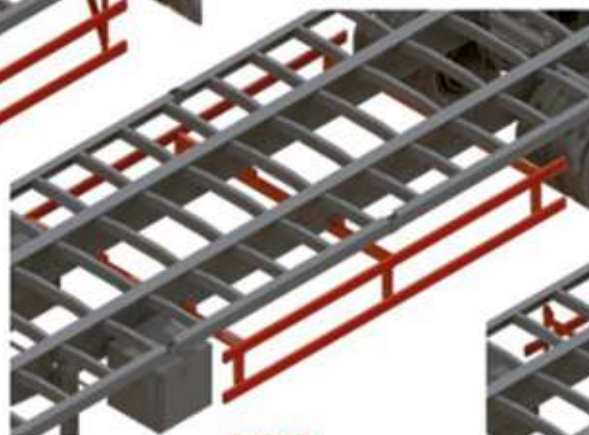

SP818



SP731

LINHA SUPORTES DE PARALAMA



SUPORTE DE PARALAMA UNIVERSAL
SP1021 - 2,150kg
SP1021B - linha leve - 1,900 kg
 (10 unidades)



SUPORTE DE PARALAMA C/3 FUROS RANDON
SP1003 - 2,130kg
SP1003B - linha leve - 1,830 kg
 (10 unidades)



SUPORTE DE PARALAMA RANDON 2019
SP821 - 1,770kg
 (10 unidades)



SUPORTE DE PARALAMA GUERRA
SP090 - 2,000kg
SP090B - linha leve - 1,870 kg
 (10 unidades)



SUPORTE DE PARALAMA LIBRELATO
SP1022 - 2,865kg
 (10 unidades)



SUPORTE DE PARALAMA FACCHINI
SP1016 - 2,190kg
SP1016B - linha leve - 2,000 kg
 (10 unidades)



SUPORTE DE PARALAMA NOMA BASE REDONDA
SP1020 - 2,600kg
 (10 unidades)



SUPORTE DE PARALAMA NOMA TITANIUM
SP822 - 795mm - 2,500kg
SP822A - 730mm - 2,200kg
 (10 unidades)



SUPORTE DE PARALAMA FACCHINI 2016
SP823 - 2,060kg
 (10 unidades)

SUPORTES



PORTA ESTEPE LINHA PESADA
SP766



PORTA ESTEPE TRUCK UNIVERSAL
SP850



SUPORTE P/BOTIJÃO DE GÁS P13
SP002
 (02 unidades)



SUPORTE DE EXTINTOR P/08, 10 E 12kg
SP004
 (02 unidades)



SUPORTE DE EXTINTOR 12 KG HORIZONTAL
SP852
 (02 unidades)



SUPORTE DE EXTINTOR 8 KG HORIZONTAL
SP852A
 (02 unidades)

COMPONENTES



CATRACA P/CINTA UNIVERSAL REFORÇADA ATÉ 100mm
CA006 - 2,700kg
 (05 unidades)



CATRACA P/CABO DE AÇO E CINTA MULTIUSO
CA007 - 3,000kg
 (05 unidades)



CATRACA MÓVEL P/CINTA ATÉ 120mm
CA010 - 3,780kg
 (05 unidades)



CATRACA P/CINTA SOLDADA ATÉ 120mm
CA012 - 3,000kg
 (05 unidades)



CATRACA FLORESTAL P/CINTA ATÉ 120mm
CA014D - DIREITO
CA014E - ESQUERDO
 (05 unidades)



CATRACA P/CINTA DO SIDER 3,5 TON
CA009 - 1,070kg
 (10 unidades)



CATRACA FLORESTAL P/CABO DE AÇO
CA016
 (05 unidades)



CABO DE TRAÇÃO P/CATRACA FLORESTAL P/CABO DE AÇO
CA017



SUPORE U AMARRAÇÃO BOBINEIRA 12,50x85x260mm ZB
SP891 - 0,600 kg
 (10 unidades)



SUPORE U AMARRAÇÃO BOBINEIRA 12,50x85x92mm ZB
SP403 - 0,260 kg
 (20 unidades)



SUPORE U AMARRAÇÃO BOBINEIRA 12,50x125x92mm ZB
SP402 - 0,310kg
 (20 unidades)



SUPORE DO ASSOALHO P/FIXAÇÃO CARGA MÓVEL
SP387 - 1,430kg
 (10 unidades)



SEPARADOR DE RODAS ARO 20" - ch. 3,75mm
SP175 - 10 furos
SP175B - 12 furos
 (02 unidades)

SEPARADOR DE RODAS ARO 22" - ch. 3,75mm
SP176 - 12 furos
 (02 unidades)



SUPORE PARA APOIO DE LONA 1400mm
SP032
 (05 unidades)



SUPORE LANTERNA LATERAL ZB
SP050 - 0,150kg
 (25 unidades)

COMPONENTES



PRESILHA "U"
P/CINTA RD 2019 ZB
SP758
(25 unidades)



PRESILHA "U"
P/CINTA ZB
SP003
(25 unidades)



PRESILHA "U"
P/CINTA GRANDE ZB
SP824
(25 unidades)



PRESILHA "W"
P/CORRENTE ZB
SP009P - 35mm
SP009 - 50mm
(25 unidades)



PRESILHA "V"
P/CORRENTE ZB
SP008P - 40mm
SP008 - 50mm
(25 unidades)



PRESILHA U CINTA
MOD FACCHINI ZB
SP915
(25 unidades)



PINO QUEBRA DEDO ZB
SP177 - 1/4" x 2"
SP181 - 5/16" x 2"
(25 unidades)



PINO QUEBRA DEDO
MONTADO C/CINTA PLÁSTICA
SP177C - 1/4" x 2"
SP181C - 5/16" x 2"
(25 unidades)



PINO QUEBRA DEDO
MONTADO C/CORRENTE
SP177R - 1/4" x 2"
SP181R - 5/16" x 2"
(25 unidades)



PINO QUEBRA DEDO
MONTADO C/CABO DE AÇO
SP177A - 1/4" x 2"
SP181A - 5/16" x 2"
(25 unidades)



JOANINHA P/BOCA DE
GRANELEIRA ZB
SP011
(25 unidades)



GRAMPO TRAVA
TOMBADOR ZB
SP014 - Ø 4,00mm - 0,040kg
SP014A - Ø 5,00mm - 0,040kg
(25 unidades)



CORRENTE P/PINO
DO FUEIRO E
JOANINHA - 170mm
SP028
(25 unidades)



PINO DO FUEIRO ZB
Ø 7,00mm
SP027A - ponta reta
SP314A - ponta dobrada
(25 unidades)



PINO DO FUEIRO
MONTADO
C/CORRENTE ZB
Ø 7,00mm
SP028A - ponta reta
SP313A - ponta dobrada
(25 unidades)



ENGATE DA CORRENTE
ANTIGO 230mm ZB
SP015 - ch. 4,25mm - 0,210kg
(50 unidades)



"S" DO ENGATE DA
CORRENTE ZB
SP029
(25 unidades)



ARGOLA DO ENGATE
DA CORRENTE ZB
SP031
(25 unidades)



CONJUNTO C/01 ENGATE,
01 "S" E 01 ARGOLA
SP015B

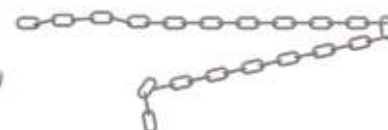

CORRENTE P/ENGATE
6,00x1310mm ZB
SP030



FIXADOR TAMPA CARROCERIA
C/PORCA ZB
SP124 - 5/8" - 0,150kg
SP124A - 3/4" - 0,100kg
(25 unidades)



REBITE DE AÇO
1/2"x1" BRUTO
SP036
(25 unidades)

COMPONENTES



COROTE D'ÁGUA C/CINTA 25L
COR030P - PRETO
(10 unidades)



**COROTE D'ÁGUA C/CINTA E
SABONETEIRA NA TAMPA 25L**
COR034P - PRETO
(10 unidades)



COROTE D'ÁGUA C/CINTA 50L
COR035 - PRETO
(02 unidades)



**CINTA DO COROTE 25L
C/DISTANCIADOR**
COR033 - ch. 1,50mm - 0,480kg
(20 unidades)



**CINTA DO COROTE 50L
C/DISTANCIADOR**
COR036 - ch. 2,65mm - 1,070kg
(10 unidades)



**TAMPA COM SUPORTE
SABONETEIRA ACOPLADO**
COR038



TORNEIRA PLÁSTICA DO COROTE
COR031
(10 unidades)



TAMPA PLÁSTICA DO COROTE 25L
COR032
(10 unidades)
TAMPA PLÁSTICA DO COROTE 50L
COR037
(10 unidades)



DISTANCIADOR DE NYLON 60mm
COR039
(20 unidades)



VOCÊ TAMBÉM
PODE ACESSAR
NOSSO SITE
ATRAVÉS DO
QR CODE



TRAVA TAMPA CAÇAMBA LEVE 9,50mm - 3,000 kg
SP567D - DIREITO
SP567E - ESQUERDO



TRAVA TAMPA CAÇAMBA PESADA 15,88mm
SP568D - DIREITO
SP568E - ESQUERDO



TRAVA TAMPA TRASEIRA CARRETA BASCULANTE 2 MOLAS
SP725 - 4,260kg



DOBRADIÇA CARRETA BASCULANTE
SP170 - 1,500kg
 (10 unidades)



CONJUNTO DOBRADIÇA CARRETA BASCULANTE 300mm
SP732 - 5,500kg
 (10 unidades)
DOBRADIÇA CARRETA BASCULANTE 300mm
SP732B - 4,690kg
 (10 unidades)



GANCHO U FECHAMENTO DOBRADIÇA BASCULANTE 300mm
SP844 - (10 unidades)



SUPORE DE APOIO DO PNEU DO ESTEPE
SP1156.3



BRAÇO SUPORE DO ESTEPE FRONTAL
SP1156.1



CATRACA DO SUPORE DO ESTEPE
SP1156.2D - DIREITO
SP1156.2E - ESQUERDO
 (05 unidades)



CONJUNTO SUPORE DO ESTEPE FRONTAL DA CAÇAMBA
SP1156D - C/CATRACA LD
SP1156E - C/CATRACA LE

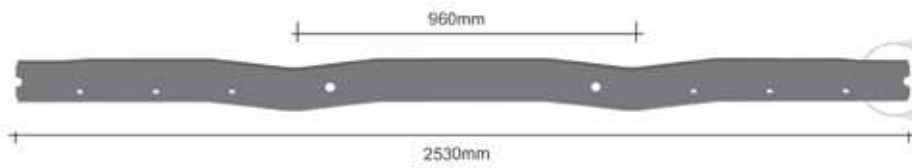

TRAVESSA TRANSVERSAL DA CARRETA RD - 2530mm
SP110 - ch. 4,25mm - 17,500kg

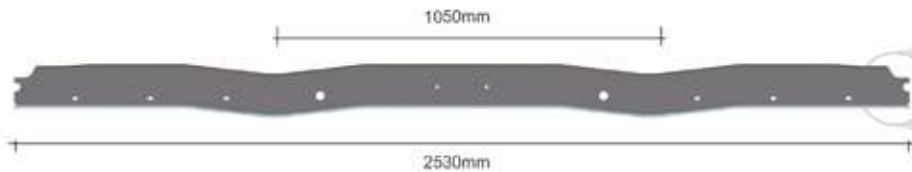

TRAVESSA TRANSVERSAL SIDER/ FRIGORÍFICO RD - 2590mm
SP514 - ch. 4,25mm - 18,000kg

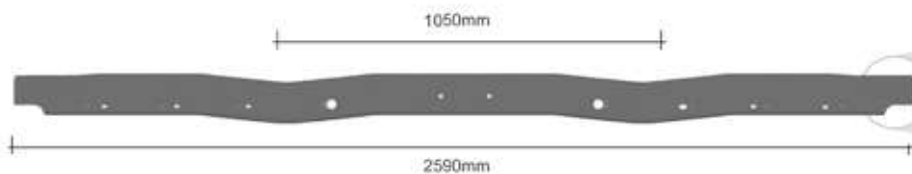

TRAVESSA TRANSVERSAL CHASSI DISTANCIADO RD - 2530mm
SP769 - ch. 4,25mm - 17,500kg

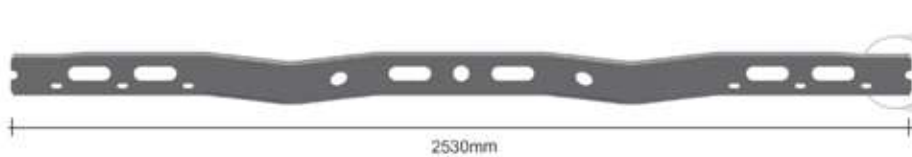

TRAVESSA TRANSVERSAL CHASSI DISTANCIADO RD - 2590mm
SP779 - ch. 4,25mm - 18,000kg



TRAVESSA TRANSVERSAL DA CARRETA NM - 2530mm
SP765 - ch. 4,25mm - 16,420kg

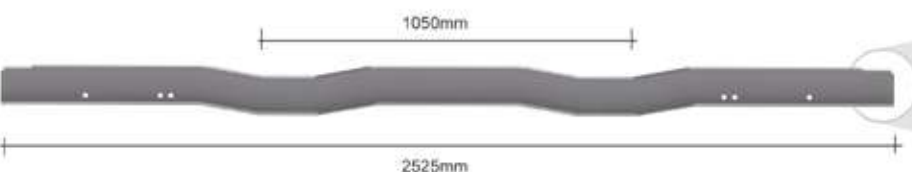

TRAVESSA TRANSVERSAL DA CARRETA GE - 2525mm
SP334 - ch. 4,25mm - 15,550kg

TRAVESSA TRANSVERSAL SIDER/FRIGORÍFICO GE - 2590mm
SP742 - ch. 4,25mm - 15,820kg

TRAVESSA TRANSVERSAL CHASSI DISTANCIADO GE - 2525mm
SP782 - ch. 4,25mm - 15,550kg

TRAVESSA TRANSVERSAL CHASSI DISTANCIADO GE - 2590mm
SP783 - ch. 4,25mm - 15,820kg



MÃO FRANCESA TRANSVERSAL CARRETA 787mm DIREITO
SP900



MÃO FRANCESA TRANSVERSAL CARRETA 787mm ESQUERDO
SP901

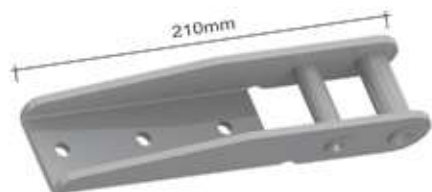

DOBRADIÇA DA TAMPA ANTIGA - 210mm
SP046 - ch. 4,25mm - 0,630kg
SP046B - SEM PINTURA
 (25 unidades)

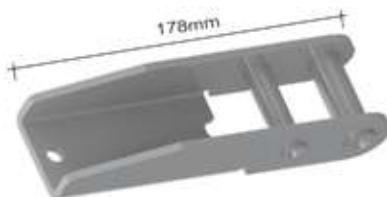

DOBRADIÇA DA TAMPA MODERNA - 178mm
SP279 - ch. 4,25mm - 0,540kg
SP279B - SEM PINTURA
 (25 unidades)



DOBRADIÇA DA TAMPA LN R 2019 - 178mm
SP730 - ch. 4,25mm - 0,540kg
SP730B - SEM PINTURA
 (25 unidades)

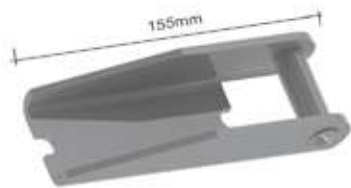

DOBRADIÇA DO TOMBADOR SUPERIOR - 155mm
SP047A - ch. 4,25mm - 0,480kg
SP047AB - SEM PINTURA
 (10 unidades)

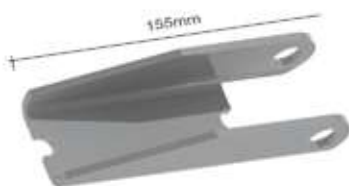

DOBRADIÇA DO TOMBADOR INFERIOR - 155mm
SP047 - ch. 4,25mm - 0,400kg
SP047B - SEM PINTURA
 (10 unidades)



DOBRADIÇA CURTA DA CARROCERIA TRUCK 110mm
SP120 - ch. 4,25mm - 0,330kg
SP120B - SEM PINTURA
 (25 unidades)



DOBRADIÇA DA CARROCERIA 150mm
SP530 - ch. 4,25mm - 0,370kg
SP530B - SEM PINTURA
 (25 unidades)

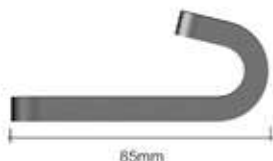

ENGATE "J" DA GRADE DA CARRETA
SP238 - ch. 8,00mm - largura 32mm - 0,220kg
 * SEM PINTURA
 (10 unidades)



ENGATE RÁPIDO DOBRADIÇA
SP048 - ch. 8,00mm - largura 32mm - 0,230kg
 * SEM PINTURA
 (50 unidades)



ENGATE "G" LINHA R FUNDIDO
SP369 - 0,200kg
SP369Z - ZINCADO BRANCO
 (30 unidades)

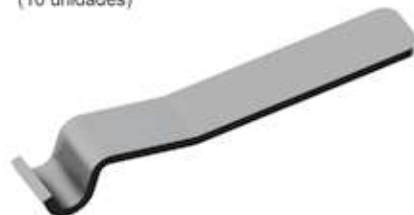

GANCHO DO TOMBADOR
SP043 - ch. 6,35mm - 0,480kg
 * SEM PINTURA
 (25 unidades)



DESLIZANTE DO TOMBADOR
SP045 - Ø12,70mm - 0,100kg
 * SEM PINTURA
 (25 unidades)



GANCHO DO TOMBADOR LN R 2019
SP740 - 0,840kg
 (04 unidades)

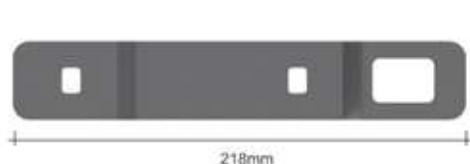

ENGATE FÊMEA DA TAMPA SUPERIOR - 218mm
SP044 - ch. 6,35mm - 0,370kg
 * SEM PINTURA
 (25 unidades)



ENGATE FÊMEA DA CARROCERIA 135mm
SP065G - ch. 6,35mm - 0,200kg
 (25 unidades)

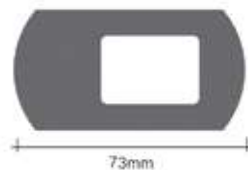

ENGATE FÊMEA DA TAMPA INFERIOR - 73mm
SP065 - ch. 6,35mm - 0,090kg
 * SEM PINTURA
 (25 unidades)



ENGATE FÊMEA LINHA R - 95mm
SP308 - ch. 6,35mm - 0,120kg
 * SEM PINTURA
 (25 unidades)



ENGATE FÊMEA DA TAMPA SUPERIOR BRASILIS
SP157 - ch. 6,35mm - 0,130kg
 * SEM PINTURA
 (25 unidades)



PRESILHA DO FUEIRO
SP034
 * SEM PINTURA
 (25 unidades)



CONJUNTO ROLETE TOMBADOR TAMPA TRASEIRA
SP040 - 0,290kg
 (10 unidades)



BOCA DE GRANELEIRA UNIVERSAL
SP010U - 2,200kg
 (10 unidades)



SUPORTE DO ARCO DA GRANELEIRA
SP042A - ch. 2,00mm - 0,230kg
 (50 unidades)



GUIA DA FOMINHA GRANELEIRA
SP041 - 0,200kg
 (25 unidades)



ARANHA DO ASSOALHO ZB
SP016 - 0,040kg
 (25 unidades)



FIXADOR CONJUNTO APARELHO LEVANTAMENTO PÉ MECÂNICO ANTIGO 330mm
SP353 - ch. 6,35mm - 4,800kg



FIXADOR CONJUNTO APARELHO LEVANTAMENTO PÉ MECÂNICO MODERNO - 265mm
SP353A - ch. 6,35mm - 3,700kg



SUPORTE U FIXAÇÃO DO PÉ MECÂNICO
SP737 - Antigo 135mm - ch. 6,35mm - 1,220kg
SP737A - Moderno 185mm - ch. 6,35mm - 1,770kg



BRAÇO DO APARELHO DE LEVANTAMENTO DA CARRETA
SP750 - 2,510kg



PARALAMA TRASEIRO
SP069D - DIREITO
SP069E - ESQUERDO
 ch. 2,00mm - 9,200kg
 (02 unidades)



PARALAMA DIANTEIRO
SP071D - DIREITO
SP071E - ESQUERDO
 ch. 2,00mm - 6,300kg
 (02 unidades)

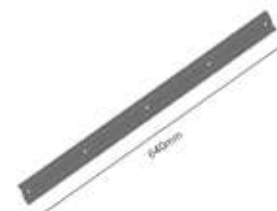

RÉGUA FIXAÇÃO PARABARRO
SP070 640mm - 0,450kg
SP070A 590mm - 0,430kg
SP070B 670mm - 0,490kg
 (10 unidades)

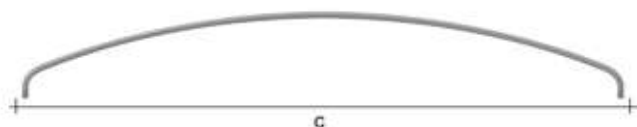

ARCO DE GRANELEIRA COMP. 2380mm
SP072A
 (06 unidades)

ARCO DE BITREM COMP. 2525mm
SP072B
 (06 unidades)

ARCO DE GRANELEIRA NOMA COMP. 2580mm
SP072C
 (06 unidades)

ARCO DA CAÇAMBA COMP. 2450mm
SP072E
 (06 unidades)

ARCO DE GRANELEIRA COMP. 2420mm - PÉ 60mm
SP072F
 (06 unidades)

ARCO DE GRANELEIRA COMP. 2400mm - PÉ 70mm
SP072G
 (06 unidades)



ARCO INTERNO GUERRA COMP. 2450mm
SP072D
 (06 unidades)

OBS: a medida informada nos arcos é por fora do tubo.

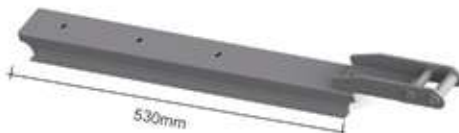

COLUNA SUPERIOR/INFERIOR DA GRADE

SP155Z	430mm	SP155D	880mm
SP155	530mm	SP155E	930mm
SP155A	580mm	SP155F	980mm
SP155B	680mm	SP155G	1080mm
SP155C	780mm		

COLUNA SUPERIOR/INFERIOR MONTADA COM DOBRADIÇA SP730

SP739Z	430mm	SP739D	880mm
SP739	530mm	SP739E	930mm
SP739A	580mm	SP739F	980mm
SP739B	680mm	SP739G	1080mm
SP739C	780mm		

COLUNA INFERIOR TOMBADOR 2019

SP738Z	430mm	SP738D	880mm
SP738	530mm	SP738E	930mm
SP738A	580mm	SP738F	980mm
SP738B	680mm	SP738G	1080mm
SP738C	780mm		



SUPORE PLACA VEÍCULO LONGO

SP803 - 30,950kg



*peça fornecida sem a faixa adesiva



imagem ilustrativa

SUPORE DO ESTEPE PARA CARRETA E BITREM

SP373 - 38,600kg

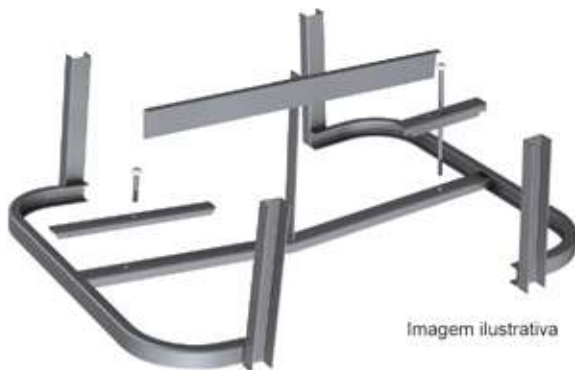

BASE INFERIOR SUPORE ESTEPE MONTADA

SP373.1 - 23,600kg



REFORÇO LATERAL - 500mm

SP373.6 - ch. 4,25mm - 2,500kg



SUPORE FIXAÇÃO RODA DISCO - 330mm

SP374.7 - ch. 4,25mm - 1,350kg



SUPORE FIXAÇÃO RODA RAIADA - 540mm

SP374.6 - ch. 4,25mm - 1,470kg



PARAFUSO 1/2"x100mm PARA RODA RAIADA ZB

SP374.8 - (10 unidades)

PARAFUSO 1/2"x397mm PARA RODA DISCO ZB

SP374.9 - (06 unidades)

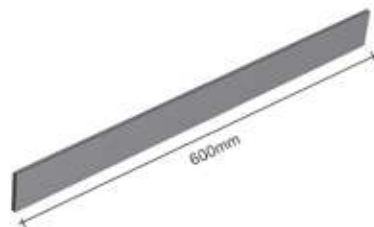

CHAPA CENTRAL DE FIXAÇÃO - 600mm

SP373.7 - 1,500kg

* SEM PINTURA



CHAPA L DE FIXAÇÃO - 1040mm

SP373.8 - 3,710kg

* SEM PINTURA



VIGUETA SUPERIOR DA TAMPA SUPERIOR

- SP103** 2960mm
- SP103A** 2420mm
- SP103B** 2220mm
- SP103C** 2320mm



VIGUETA SUPERIOR DA TAMPA SUPERIOR MODERNA

- SP158** 2970mm
- SP158A** 2430mm
- SP158B** 2230mm
- SP158C** 2330mm



VIGUETA SUPERIOR DA TAMPA INFERIOR

- SP101** 2960mm
- SP101A** 2420mm
- SP101B** 2220mm
- SP101C** 2320mm



VIGUETA INFERIOR DA TAMPA SUPERIOR/INFERIOR

- SP102** 2960mm
- SP102A** 2420mm
- SP102B** 2220mm
- SP102C** 2320mm



CANTONEIRA DO ASSOALHO - 3000mm

- SP216A** - ch. 2,00mm - 2.900kg (05 unidades)



PERFIL UNIÃO DO ASSOALHO - 2420mm

- SP221** - ch. 2,00mm - 5.163kg (02 unidades)



SUPOORTE DA SINALEIRA 145x2450mm

- SP225** - ch. 3,75mm - 19.040kg

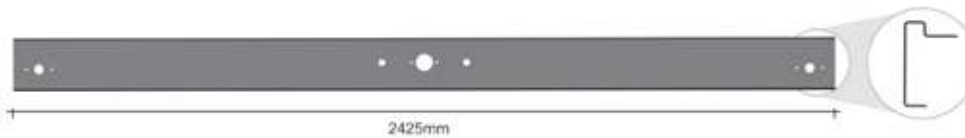

PERFIL DIANTEIRO DA CARRETA BRASILIS/ LINHA R - 2425mm
SP219A - ch. 4,25mm - 23,490kg

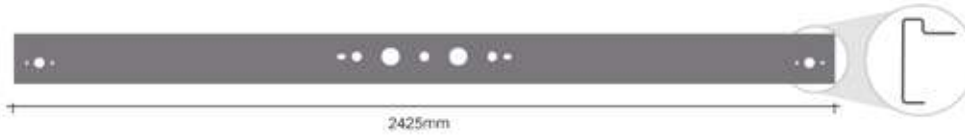

PERFIL DIANTEIRO DA CARRETA LINHA R ASSOALHO MADEIRA - 2425mm
SP219B - ch. 4,25mm - 23,340kg

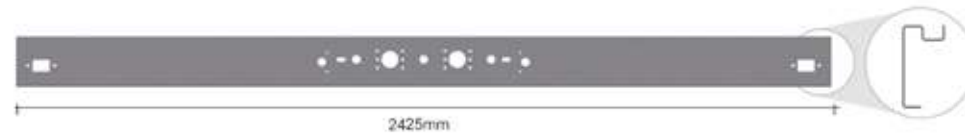

PERFIL DIANTEIRO DA CARRETA NEW R FREIOS ABS ASSOALHO DE FERRO - 2425mm
SP219C - ch. 4,25mm - 23,320kg

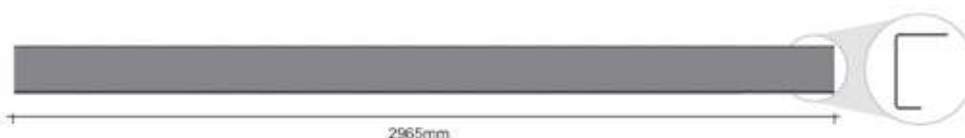

PERFIL LATERAL DA CARRETA SEM FURAÇÃO
SP217 - 2965mm - ch. 4,25mm - 25,000kg
SP217A - 2225mm - ch. 4,25mm - 18,760kg
SP217B - 2430mm - ch. 4,25mm - 20,440kg
SP217C - 2325mm - ch. 4,25mm - 19,600kg



PERFIL LATERAL DA CARRETA COM FURAÇÃO
SP372 - 2965mm - ch. 4,25mm - 25,000kg
SP372A - 2225mm - ch. 4,25mm - 18,760kg
SP372B - 2430mm - ch. 4,25mm - 20,440kg
SP372C - 2325mm - ch. 4,25mm - 19,600kg



PERFIL LATERAL DA CARRETA PARA ASSOALHO DE FERRO
SP389 - 2965mm - ch. 4,25mm - 25,700kg
SP389A - 2225mm - ch. 4,25mm - 18,000kg
SP389B - 2430mm - ch. 4,25mm - 19,720kg
SP389C - 2325mm - ch. 4,25mm - 19,600kg



PERFIL TRASEIRO DA CARRETA SEM FURAÇÃO - 2430mm
SP218 - ch. 4,25mm - 20,655kg
PERFIL TRASEIRO DA CARRETA COM FURAÇÃO - 2430mm
SP218A - ch. 4,25mm - 20,655kg



PERFIL TRASEIRO DA CARRETA COM FURAÇÃO LN R 2019 - 2430mm
SP778 - ch. 4,25mm - 23,330kg



PERFIL TRASEIRO DA CARRETA PARA ASSOALHO DE FERRO - 2430mm
SP390 - ch. 4,25mm - 24,300kg

CARRETAS LINHAS ATÉ 2005, BRASILIS E LINHA R

FUEIROS CHAPA DE ENCOSTO COM FRISO



FRONTAL SUPERIOR COM FRISO CARRETA BRASILIS

SP287Z	550mm	SP287D	1000mm
SP287	650mm	SP287E	1050mm
SP287A	700mm	SP287F	1100mm
SP287B	800mm	SP287G	1200mm
SP287C	900mm		

FRONTAL SUPERIOR COM FRISO CARRETA ATÉ 2005 (presilha 18mm)

SP114Z	550mm	SP114B	800mm
SP114	650mm	SP114C	900mm
SP114A	700mm	SP114D	1000mm



FUEIRO LATERAL SUPERIOR COM FRISO BRASILIS

SP281Z	95x550mm
SP281	95x650mm
SP281A	95x700mm
SP281B	95x800mm
SP281C	95x900mm
SP281D	95x1000mm
SP281E	95x1050mm
SP281F	95x1100mm
SP281G	95x1200mm

FUEIRO LATERAL SUPERIOR C/FRISO ATÉ 2005 (presilha 18mm)

SP052Z	95x550mm
SP052	95x650mm
SP052A	95x700mm
SP052B	95x800mm
SP052C	95x900mm
SP052D	95x1000mm

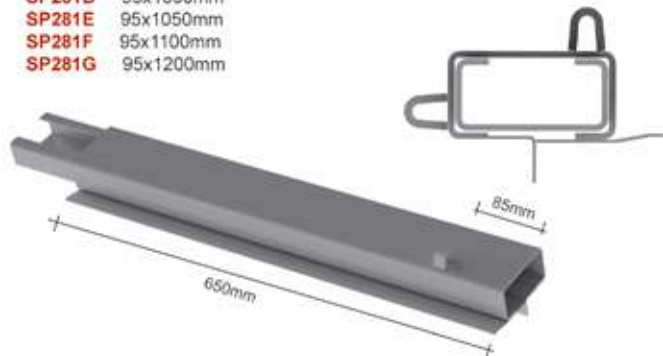

FUEIRO DE CANTO SUPERIOR DIREITO/ESQUERDO COM FRISO BRASILIS

SP283Z.D	95x550mm	SP283Z.E	95x550mm
SP283D	95x650mm	SP283E	95x650mm
SP283A.D	95x700mm	SP283A.E	95x700mm
SP283B.D	95x800mm	SP283B.E	95x800mm
SP283C.D	95x900mm	SP283C.E	95x900mm
SP283D.D	95x1000mm	SP283D.E	95x1000mm
SP283E.D	95x1050mm	SP283E.E	95x1050mm
SP283F.D	95x1100mm	SP283F.E	95x1100mm
SP283G.D	95x1200mm	SP283G.E	95x1200mm

FUEIRO DE CANTO SUPERIOR DIREITO/ESQUERDO COM FRISO ATÉ 2005 (presilha 18mm)

SP057Z.D	95x550mm	SP057Z.E	95x550mm
SP057D	95x650mm	SP057E	95x650mm
SP057A.D	95x700mm	SP057A.E	95x700mm
SP057B.D	95x800mm	SP057B.E	95x800mm
SP057C.D	95x900mm	SP057C.E	95x900mm
SP057D.D	95x1000mm	SP057D.E	95x1000mm



FRONTAL INFERIOR COM FRISO CARRETA ATÉ 2005/BRASILIS

SP288Y	500mm	SP288C	900mm
SP288Z	550mm	SP288D	1000mm
SP288	650mm	SP288E	1050mm
SP288A	700mm	SP288F	1100mm
SP288B	800mm	SP288G	1200mm



FRONTAL SUPERIOR CURVADO LINHA R

SP347Z	550mm
SP347	650mm
SP347A	700mm
SP347B	800mm
SP347C	900mm
SP347D	1000mm

FRONTAL INFERIOR CURVADO LINHA R

SP348Z	550mm
SP348	650mm
SP348A	700mm
SP348B	800mm
SP348C	900mm
SP348D	1000mm



FUEIRO LATERAL INFERIOR COM FRISO ATÉ 2005/BRASILIS

SP282Y	95x500mm	SP282C	95x900mm
SP282Z	95x550mm	SP282D	95x1000mm
SP282	95x650mm	SP282E	95x1050mm
SP282A	95x700mm	SP282F	95x1100mm
SP282B	95x800mm	SP282G	95x1200mm



FUEIRO DE CANTO INFERIOR DIREITO/ESQUERDO COM FRISO ATÉ 2005/BRASILIS

SP284Y.D	95x500mm	SP284Y.E	95x500mm
SP284Z.D	95x550mm	SP284Z.E	95x550mm
SP284D	95x650mm	SP284E	95x650mm
SP284A.D	95x700mm	SP284A.E	95x700mm
SP284B.D	95x800mm	SP284B.E	95x800mm
SP284C.D	95x900mm	SP284C.E	95x900mm
SP284D.D	95x1000mm	SP284D.E	95x1000mm
SP284E.D	95x1050mm	SP284E.E	95x1050mm
SP284F.D	95x1100mm	SP284F.E	95x1100mm
SP284G.D	95x1200mm	SP284G.E	95x1200mm

CARRETAS LINHA 2002 À 2005

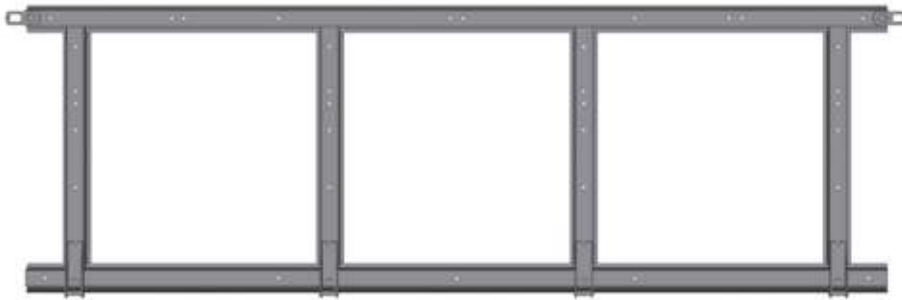

GRADE DO TOMBADOR SUPERIOR

GR002	650x2420mm
GR002A	700x2420mm
GR002B	800x2420mm
GR002C	900x2420mm
GR002D	1000x2420mm



GRADE DO TOMBADOR INFERIOR

GR001	650x2420mm
GR001A	700x2420mm
GR001B	800x2420mm
GR001C	900x2420mm
GR001D	1000x2420mm

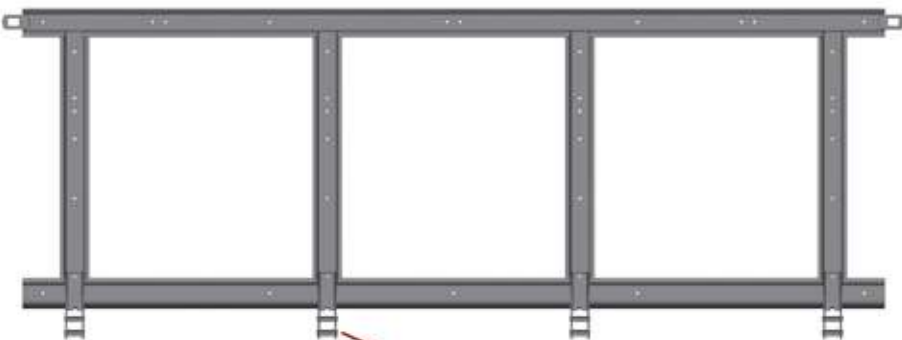

DOBRADIÇA
SP279

GRADE TRASEIRA CARGA SECA

GR001Y	- 500x2420mm
GR001Z	- 550x2420mm

GRADE LATERAL SUPERIOR BITREM

GR004	650x2220mm
GR004A	700x2220mm
GR004B	800x2220mm
GR004C	900x2220mm
GR004D	1000x2220mm

GRADE LATERAL SUPERIOR CARRETA

GR005	650x2960mm
GR005A	700x2960mm
GR005B	800x2960mm
GR005C	900x2960mm
GR005D	1000x2960mm

GRADE LATERAL SUPERIOR BITREM 7,50m

GR022	650x2320mm
GR022A	700x2320mm
GR022B	800x2320mm
GR022C	900x2320mm
GR022D	1000x2320mm

GRADE LATERAL INFERIOR BITREM

GR003	650x2220mm
GR003A	700x2220mm
GR003B	800x2220mm
GR003C	900x2220mm
GR003D	1000x2220mm

GRADE LATERAL INFERIOR CARRETA

GR006	650x2960mm
GR006A	700x2960mm
GR006B	800x2960mm
GR006C	900x2960mm
GR006D	1000x2960mm

GRADE LATERAL INFERIOR BITREM 7,50m

GR023	650x2320mm
GR023A	700x2320mm
GR023B	800x2320mm
GR023C	900x2320mm
GR023D	1000x2320mm



GRADE LATERAL CARGA SECA

GR006Y	- 500x2960mm
GR006Z	- 550x2960mm

CONJUNTO DO TOMBADOR INFERIOR DA CARRETA

SP290	- 5.870kg
	(02 unidades)

CARRETAS BRASILIS E LINHA R



GRADE DO TOMBADOR SUPERIOR BRASILIS/LINHA R

GR009	650x2430mm	GR009D	1000x2430mm
GR009A	700x2430mm	GR009E	1050x2430mm
GR009B	800x2430mm	GR009F	1100x2430mm
GR009C	900x2430mm	GR009G	1200x2430mm



GRADE DO TOMBADOR INFERIOR

GR001	650x2420mm	GR001D	1000x2420mm
GR001A	700x2420mm	GR001E	1050x2420mm
GR001B	800x2420mm	GR001F	1100x2420mm
GR001C	900x2420mm	GR001G	1200x2420mm

GRADE TRASEIRA CARGA SECA

GR001Y	500x2420mm
GR001Z	550x2420mm

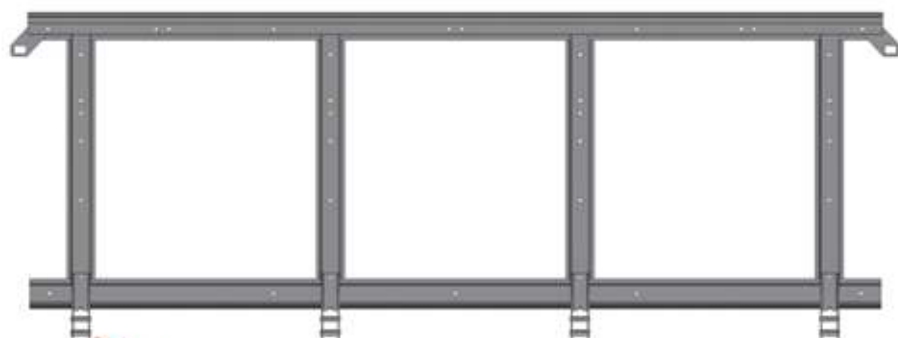

GRADE LATERAL SUPERIOR BITREM BRASILIS/LINHA R

GR007	650x2230mm	GR007D	1000x2230mm
GR007A	700x2230mm	GR007E	1050x2230mm
GR007B	800x2230mm	GR007F	1100x2230mm
GR007C	900x2230mm	GR007G	1200x2230mm

GRADE LATERAL SUPERIOR CARRETA BRASILIS/LINHA R

GR008	650x2970mm	GR008D	1000x2970mm
GR008A	700x2970mm	GR008E	1050x2970mm
GR008B	800x2970mm	GR008F	1100x2970mm
GR008C	900x2970mm	GR008G	1200x2970mm

GRADE LATERAL SUPERIOR BITREM 7,50m BRASILIS/LINHA R

GR025	650x2330mm	GR025D	1000x2330mm
GR025A	700x2330mm	GR025E	1050x2330mm
GR025B	800x2330mm	GR025F	1100x2330mm
GR025C	900x2330mm	GR025G	1200x2330mm

DOBRADIÇA SP279

GRADE LATERAL SUPERIOR DA CARRETA BRASILIS/LINHA R

GR051	650x2430mm	GR051D	1000x2430mm
GR051A	700x2430mm	GR051E	1050x2430mm
GR051B	800x2430mm	GR051F	1100x2430mm
GR051C	900x2430mm	GR051G	1200x2430mm

GRADE LATERAL INFERIOR BITREM

GR003	650x2220mm	GR003D	1000x2220mm
GR003A	700x2220mm	GR003E	1050x2220mm
GR003B	800x2220mm	GR003F	1100x2220mm
GR003C	900x2220mm	GR003G	1200x2220mm

GRADE LATERAL INFERIOR CARRETA

GR006	650x2960mm	GR006D	1000x2960mm
GR006A	700x2960mm	GR006E	1050x2960mm
GR006B	800x2960mm	GR006F	1100x2960mm
GR006C	900x2960mm	GR006G	1200x2960mm

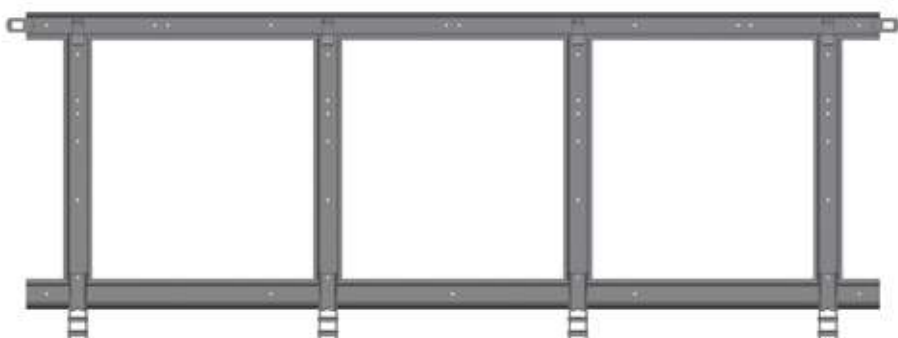

GRADE LATERAL INFERIOR CARRETA BRASILIS/LINHA R

GR052	650x2420mm	GR052D	1000x2420mm
GR052A	700x2420mm	GR052E	1050x2420mm
GR052B	800x2420mm	GR052F	1100x2420mm
GR052C	900x2420mm	GR052G	1200x2420mm

GRADE LATERAL CARGA SECA

GR006Y	500x2960mm
GR006Z	550x2960mm

GRADE LATERAL INFERIOR BITREM 7,50m

GR023	650x2320mm	GR023D	1000x2320mm
GR023A	700x2320mm	GR023E	1050x2320mm
GR023B	800x2320mm	GR023F	1100x2320mm
GR023C	900x2320mm	GR023G	1200x2320mm

CONJUNTO DO TOMBADOR INFERIOR DA CARRETA

SP290 - 5,870kg
(02 unidades)



CARRETAS LINHA R 2019 ECOPLATE 2

FUEIROS CHAPA DE ENCOSTO RETA



FRONTAL SUPERIOR CHAPA RETA CARRETA LN R 2019

SP743Z	550mm	SP743E	1050mm
SP743	650mm	SP743F	1100mm
SP743B	800mm	SP743G	1200mm
SP743D	1000mm		



FRONTAL INFERIOR CHAPA RETA CARRETA LN R 2019

SP744Y	500mm	SP744D	1000mm
SP744Z	550mm	SP744E	1050mm
SP744	650mm	SP744F	1100mm
SP744B	800mm	SP744G	1200mm



FUEIRO LATERAL SUPERIOR CHAPA RETA

SP751Z	95x550mm	SP751E	95x1050mm
SP751	95x650mm	SP751F	95x1100mm
SP751B	95x800mm	SP751G	95x1200mm
SP751D	95x1000mm		

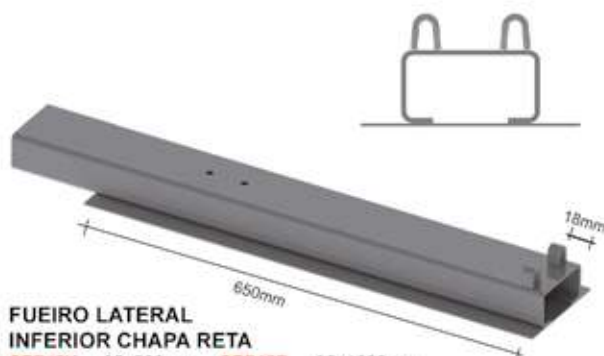

FUEIRO LATERAL INFERIOR CHAPA RETA

SP745Y	95x500mm	SP745D	95x1000mm
SP745Z	95x550mm	SP745E	95x1050mm
SP745	95x650mm	SP745F	95x1100mm
SP745B	95x800mm	SP745G	95x1200mm



FUEIRO DE CANTO SUPERIOR DIREITO/ESQUERDO CHAPA RETA

SP753Z.D	95x550mm	SP753Z.E	95x550mm
SP753D	95x650mm	SP753E	95x650mm
SP753B.D	95x800mm	SP753B.E	95x800mm
SP753D.D	95x1000mm	SP753D.E	95x1000mm
SP753E.D	95x1050mm	SP753E.E	95x1050mm
SP753F.D	95x1100mm	SP753F.E	95x1100mm
SP753G.D	95x1200mm	SP753G.E	95x1200mm



FUEIRO DE CANTO INFERIOR DIREITO/ESQUERDO CHAPA RETA

SP747Y.D	95x500mm	SP747Y.E	95x500mm
SP747Z.D	95x550mm	SP747Z.E	95x550mm
SP747D	95x650mm	SP747E	95x650mm
SP747B.D	95x800mm	SP747B.E	95x800mm
SP747D.D	95x1000mm	SP747D.E	95x1000mm
SP747E.D	95x1050mm	SP747E.E	95x1050mm
SP747F.D	95x1100mm	SP747F.E	95x1100mm
SP747G.D	95x1200mm	SP747G.E	95x1200mm



CAIXA DO FUEIRO 130mm
SP063 - ch. 6,35mm - 1,950kg



ENCAIXE DO FUEIRO SUPERIOR
SP052.1 - ch. 3,75mm - 0,970kg

CARRETAS LINHA R 2019 ECOPLATE 2



GRADE DO TOMBADOR SUPERIOR LN R 2019

GR103	650x2430mm
GR103B	800x2430mm
GR103D	1000x2430mm
GR103E	1050x2430mm
GR103F	1100x2430mm
GR103G	1200x2430mm



GRADE DO TOMBADOR INFERIOR LN R 2019

GR101	650x2420mm
GR101B	800x2420mm
GR101D	1000x2420mm
GR101E	1050x2420mm
GR101F	1100x2420mm
GR101G	1200x2420mm



GRADE TRASEIRA CARGA SECA LN R 2019

GR101Y	- 500x2420mm
GR101Z	- 550x2420mm

GRADE LATERAL SUPERIOR BITREM LN R 2019

GR108	650x2230mm
GR108B	800x2230mm
GR108D	1000x2230mm
GR108E	1050x2230mm
GR108F	1100x2230mm
GR108G	1200x2230mm

GRADE LATERAL SUPERIOR CARRETA LN R 2019

GR102	650x2970mm
GR102B	800x2970mm
GR102D	1000x2970mm
GR102E	1050x2970mm
GR102F	1100x2970mm
GR102G	1200x2970mm

DOBRADIÇA SP730

GRADE LATERAL SUPERIOR DA CARRETA LN R 2019

GR110	650x2430mm
GR110B	800x2430mm
GR110D	1000x2430mm
GR110E	1050x2430mm
GR110F	1100x2430mm
GR110G	1200x2430mm

GRADE LATERAL SUPERIOR BITREM 7,50m LN R 2019

GR109	650x2330mm
GR109B	800x2330mm
GR109D	1000x2330mm
GR109E	1050x2330mm
GR109F	1100x2330mm
GR109G	1200x2330mm

GRADE LATERAL INFERIOR BITREM LN R 2019

GR099	650x2220mm
GR099B	800x2220mm
GR099D	1000x2220mm
GR099E	1050x2220mm
GR099F	1100x2220mm
GR099G	1200x2220mm

GRADE LATERAL INFERIOR CARRETA LN R 2019

GR100	650x2960mm
GR100B	800x2960mm
GR100D	1000x2960mm
GR100E	1050x2960mm
GR100F	1100x2960mm
GR100G	1200x2960mm



GRADE LATERAL INFERIOR CARRETA LN R 2019

GR111	650x2420mm
GR111B	800x2420mm
GR111D	1000x2420mm
GR111E	1050x2420mm
GR111F	1100x2420mm
GR111G	1200x2420mm

GRADE LATERAL CARGA SECA LN R 2019

GR100Y	- 500x2960mm
GR100Z	- 550x2960mm

GRADE LATERAL INFERIOR BITREM 7,50m LN R 2019

GR112	650x2320mm
GR112B	800x2320mm
GR112D	1000x2320mm
GR112E	1050x2320mm
GR112F	1100x2320mm
GR112G	1200x2320mm

CONJUNTO DO TOMBADOR INFERIOR DA CARRETA LN R 2019

SP741 - 7,670kg
(02 unidades)



FUEIROS LARGOS P/CARRETAS ESPECIAIS ATÉ 2005, BRASILIS E LINHA R

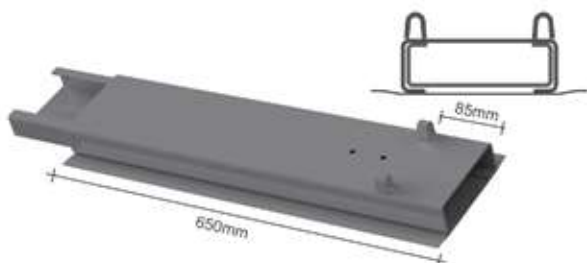

FUEIRO LATERAL SUPERIOR C/FRISO LARGO

SP405	145x650mm
SP405B	145x800mm
SP405C	145x900mm
SP405D	145x1000mm
SP405E	145x1050mm
SP405F	145x1100mm
SP405G	145x1200mm

FUEIRO LATERAL SUPERIOR C/FRISO LARGO ATÉ 2005 (presilha 18mm)

SP198	145x650mm
SP198B	145x800mm
SP198C	145x900mm
SP198D	145x1000mm

FUEIRO LATERAL INFERIOR C/FRISO LARGO

SP431Y	145x500mm	SP431D	145x1000mm
SP431Z	145x550mm	SP431E	145x1050mm
SP431	145x650mm	SP431F	145x1100mm
SP431B	145x800mm	SP431G	145x1200mm
SP431C	145x900mm		

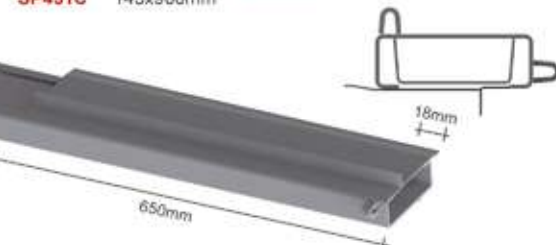

FUEIRO DE CANTO SUPERIOR C/FRISO LARGO DIREITO/ESQUERDO

SP406D	145x650mm	SP406E	145x650mm
SP406B.D	145x800mm	SP406B.E	145x800mm
SP406C.D	145x900mm	SP406C.E	145x900mm
SP406D.D	145x1000mm	SP406D.E	145x1000mm
SP406E.D	145x1050mm	SP406E.E	145x1050mm
SP406F.D	145x1100mm	SP406F.E	145x1100mm
SP406G.D	145x1200mm	SP406G.E	145x1200mm

FUEIRO DE CANTO INFERIOR C/FRISO LARGO DIREITO/ESQUERDO

SP432Y.D	145x500mm	SP432Y.E	145x500mm
SP432Z.D	145x550mm	SP432Z.E	145x550mm
SP432D	145x650mm	SP432E	145x650mm
SP432B.D	145x800mm	SP432B.E	145x800mm
SP432C.D	145x900mm	SP432C.E	145x900mm
SP432D.D	145x1000mm	SP432D.E	145x1000mm
SP432E.D	145x1050mm	SP432E.E	145x1050mm
SP432F.D	145x1100mm	SP432F.E	145x1100mm
SP432G.D	145x1200mm	SP432G.E	145x1200mm

FUEIRO DE CANTO SUPERIOR C/FRISO LARGO DIREITO/ESQUERDO ATÉ 2005 (presilha 18mm)

SP203D	145x650mm	SP203E	145x650mm
SP203B.D	145x800mm	SP203B.E	145x800mm
SP203C.D	145x900mm	SP203C.E	145x900mm
SP203D.D	145x1000mm	SP203D.E	145x1000mm

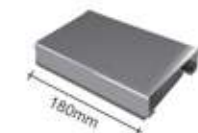

ENCAIXE DO FUEIRO SUPERIOR LARGO

SP198.1 - ch. 3,75mm - 1,210kg



CAIXA DO FUEIRO LARGO

SP199 - ch. 6,35mm - 2,600kg

FUEIROS LARGOS P/CARRETAS ESPECIAIS LN R 2019



FUEIRO LATERAL SUPERIOR CHAPA RETA LARGO

SP752	145x650mm	SP752E	145x1050mm
SP752B	145x800mm	SP752F	145x1100mm
SP752C	145x900mm	SP752G	145x1200mm
SP752D	145x1000mm		



FUEIRO LATERAL INFERIOR CHAPA RETA LARGO

SP746	145x650mm	SP746E	145x1050mm
SP746B	145x800mm	SP746F	145x1100mm
SP746C	145x900mm	SP746G	145x1200mm
SP746D	145x1000mm		



FUEIRO DE CANTO SUPERIOR CHAPA RETA LARGO DIREITO/ESQUERDO

SP748D	145x650mm	SP748E	145x650mm
SP748B.D	145x800mm	SP748B.E	145x800mm
SP748C.D	145x900mm	SP748C.E	145x900mm
SP748D.D	145x1000mm	SP748D.E	145x1000mm
SP748E.D	145x1050mm	SP748E.E	145x1050mm
SP748F.D	145x1100mm	SP748F.E	145x1100mm
SP748G.D	145x1200mm	SP748G.E	145x1200mm



FUEIRO DE CANTO INFERIOR CHAPA RETA LARGO DIREITO/ESQUERDO

SP749D	145x650mm	SP749E	145x650mm
SP749B.D	145x800mm	SP749B.E	145x800mm
SP749C.D	145x900mm	SP749C.E	145x900mm
SP749D.D	145x1000mm	SP749D.E	145x1000mm
SP749E.D	145x1050mm	SP749E.E	145x1050mm
SP749F.D	145x1100mm	SP749F.E	145x1100mm
SP749G.D	145x1200mm	SP749G.E	145x1200mm

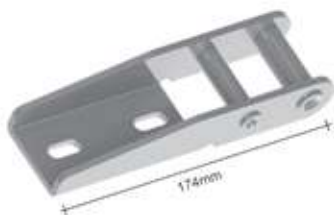

**DOBRADIÇA DA TAMP
MODERNA - 174mm**
SP350 - ch. 4,25mm - 0,500kg
SP350B - SEM PINTURA
(25 unidades)



**DOBRADIÇA DO TOMBADOR
INFERIOR MODERNA - 150mm**
SP366 - ch. 4,25mm - 0,370kg
SP366B - SEM PINTURA
(10 unidades)



**DOBRADIÇA DO TOMBADOR
SUPERIOR MODERNA - 150mm**
SP365 - ch. 4,25mm - 0,450kg
SP365B - SEM PINTURA
(10 unidades)



**DOBRADIÇA DA TAMP
MOD ESTRADA 174mm**
SP902 - ch. 4,25mm - 0,540kg
SP902B - SEM PINTURA
(25 unidades)



**ENGATE FÊMEA TAMP
SUPERIOR TECNO 5**
SP292 - ch. 6,35mm - 0,160kg
* SEM PINTURA
(25 unidades)



**ENGATE FÊMEA TAMP
INFERIOR TECNO 10**
SP511 - ch. 6,35mm - 0,160kg
* SEM PINTURA
(25 unidades)



**ENGATE FÊMEA TAMP
SUP/INF TECNO 10**
SP293 - ch. 6,35mm - 0,150kg
* SEM PINTURA
(25 unidades)



**ENGATE FÊMEA TAMP
SUPERIOR ESTRADA 2023**
SP911 - ch. 6,35mm - 0,290kg
* SEM PINTURA
(25 unidades)



**ENGATE FÊMEA TAMP
SUP/INF MOD GE/RDF**
SP906 - ch. 6,35mm - 0,190kg
* SEM PINTURA
(25 unidades)



**ENGATE FÊMEA TAMP
INFERIOR ESTRADA 2023**
SP912 - ch. 6,35mm - 0,150kg
* SEM PINTURA
(25 unidades)



**ENGATE FÊMEA INFERIOR
TAMP SUPERIOR GE/RDF**
SP907 - ch. 6,35mm - 0,260kg
* SEM PINTURA
(25 unidades)



GANCHO DO TOMBADOR
SP291 - ch. 6,35mm - 0,420kg
* SEM PINTURA
(25 unidades)

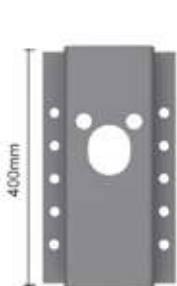

**FIXADOR CONJUNTO APARELHO
LEVANTAMENTO PÉ MECÂNICO
MODERNO 400mm**
SP367 - ch. 6,35mm - 5,700kg

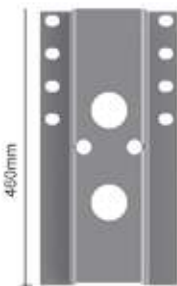

**FIXADOR CONJUNTO
APARELHO LEVANTAMENTO
PÉ MECÂNICO 460mm**
SP496 - ch. 6,35mm - 7,000kg



RÉGUA FIXAÇÃO PARABARRO 695mm
SP092 - 0,500kg
(10 unidades)



BOCA DE GRANELEIRA
SP035 - 2,000kg
(10 unidades)



**COLUNA SUPERIOR/INFERIOR
DA GRADE**

SP204Z	450mm	SP204D	900mm
SP204	550mm	SP204E	950mm
SP204A	600mm	SP204F	1000mm
SP204B	700mm	SP204G	1100mm
SP204C	800mm		

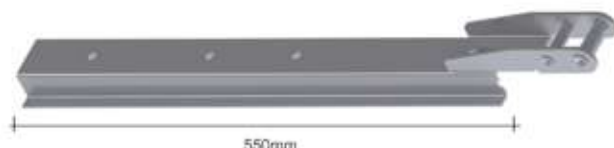

**COLUNA SUPERIOR/INFERIOR DA GRADE
MONTADA COM DOBRADIÇA SP350**

SP770Z	450mm	SP770D	900mm
SP770	550mm	SP770E	950mm
SP770A	600mm	SP770F	1000mm
SP770B	700mm	SP770G	1100mm
SP770C	800mm		



VIGUETA SUPERIOR TAMPA SUPERIOR MADEIRA

SP208 2965mm
SP208A 2430mm
SP208B 2212mm

VIGUETA SUPERIOR TAMPA SUPERIOR POLIPROPILENO

SP209 2965mm
SP209A 2430mm
SP209B 2212mm

VIGUETA SUPERIOR TAMPA INFERIOR MADEIRA

SP105 2965mm
SP105A 2430mm
SP105B 2212mm

VIGUETA SUPERIOR TAMPA INFERIOR POLIPROPILENO

SP207 2965mm
SP207A 2430mm
SP207B 2212mm

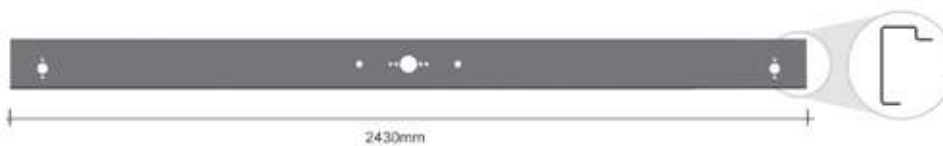

PERFIL DIANTEIRO DA CARRETA TECNO 5 - 2430mm

SP223A - ch. 4,25mm - 24,450kg

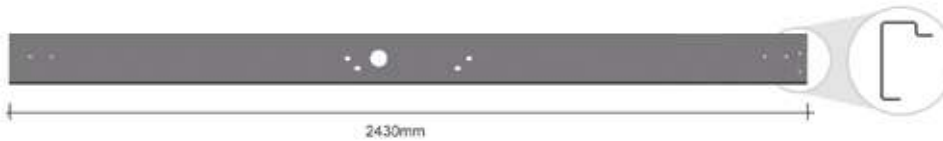

PERFIL DIANTEIRO DA CARRETA TECNO 5 FREIO ABS - 2430mm

SP223B - ch. 4,25mm - 24,450kg

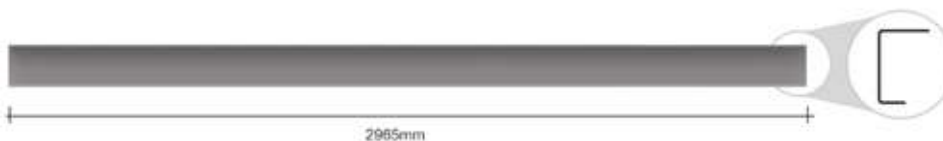

PERFIL LATERAL DA CARRETA SEM FURAÇÃO

SP234 - 2965mm - ch. 4,25mm - 25,000kg
SP234A - 2212mm - ch. 4,25mm - 18,650kg
SP234B - 2430mm - ch. 4,25mm - 20,650kg

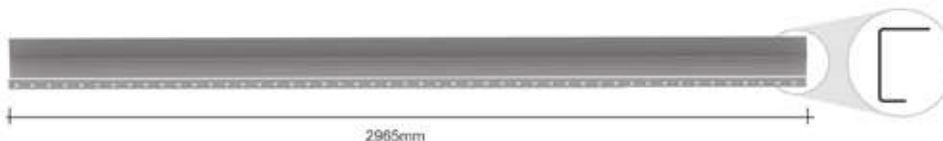

PERFIL LATERAL DA CARRETA COM FURAÇÃO

SP385 - 2965mm - ch. 4,25mm - 25,000kg
SP385A - 2212mm - ch. 4,25mm - 18,650kg
SP385B - 2430mm - ch. 4,25mm - 20,650kg



PERFIL LATERAL DA CARRETA PARA ASSOALHO DE FERRO

SP780 - 2965mm - ch. 4,25mm - 25,650kg
SP780A - 2212mm - ch. 4,25mm - 19,000kg
SP780B - 2430mm - ch. 4,25mm - 20,820kg



PERFIL TRASEIRO DA CARRETA SEM FURAÇÃO - 2430mm

SP222 - ch. 4,25mm - 20,650kg

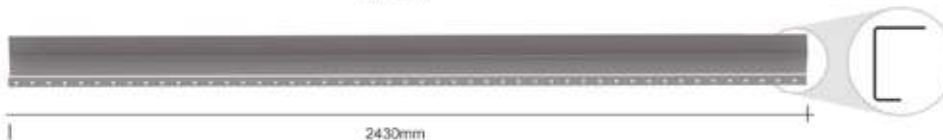

PERFIL TRASEIRO DA CARRETA COM FURAÇÃO - 2430mm

SP222A - ch. 4,25mm - 20,650kg



PERFIL TRASEIRO DA CARRETA PARA ASSOALHO DE FERRO - 2430mm

SP781 - ch. 4,25mm - 20,820kg



SUPORTE DA SINALEIRA 145x2350mm

SP724 - ch. 3,75mm - 15,640kg

CARRETAS LINHA TECNO 5 TAMPA DE MADEIRA E POLIPROPILENO 2008

FRONTAIS E FUEIROS CHAPA DE ENCOSTO COM FRISO



FRONTAL SUPERIOR COM FRISO DA CARRETA GRANELEIRA

- SP264 650mm
- SP264B 800mm
- SP264D 1000mm
- SP264E 1050mm
- SP264F 1100mm
- SP264G 1200mm



FRONTAL INFERIOR COM FRISO DA CARRETA GRANELEIRA

- SP263Z 550mm
- SP263 650mm
- SP263B 800mm
- SP263D 1000mm
- SP263E 1050mm
- SP263F 1100mm
- SP263G 1200mm

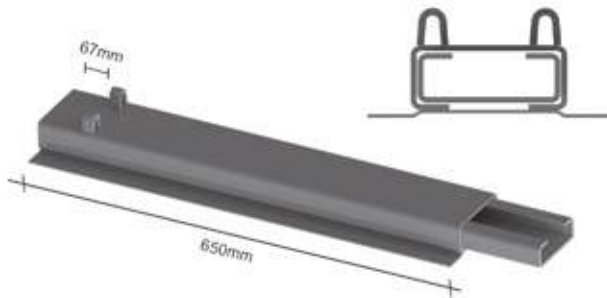

FUEIRO LATERAL SUPERIOR COM FRISO

- SP266 104x650mm
- SP266B 104x800mm
- SP266D 104x1000mm
- SP266E 104x1050mm
- SP266F 104x1100mm
- SP266G 104x1200mm

FUEIRO LATERAL INFERIOR COM FRISO

- SP267Z 104x550mm
- SP267 104x650mm
- SP267B 104x800mm
- SP267D 104x1000mm
- SP267E 104x1050mm
- SP267F 104x1100mm
- SP267G 104x1200mm

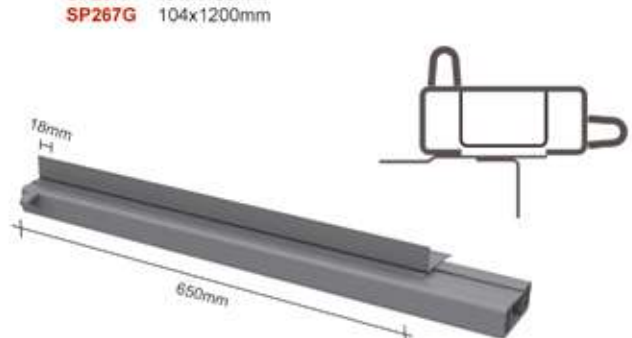
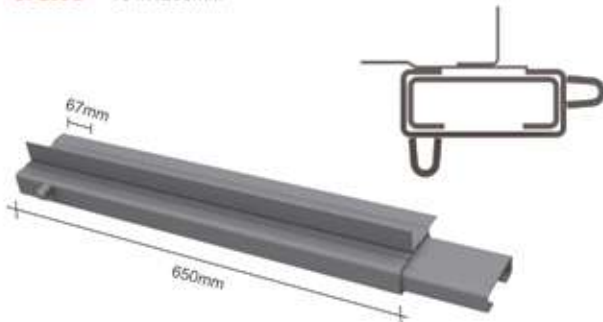

FUEIRO CANTO SUPERIOR DIREITO/ESQUERDO COM FRISO

- | | |
|---------------------|---------------------|
| SP268D 104x650mm | SP268E 104x650mm |
| SP268B.D 104x800mm | SP268B.E 104x800mm |
| SP268D.D 104x1000mm | SP268D.E 104x1000mm |
| SP268E.D 104x1050mm | SP268E.E 104x1050mm |
| SP268F.D 104x1100mm | SP268F.E 104x1100mm |
| SP268G.D 104x1200mm | SP268G.E 104x1200mm |

FUEIRO CANTO INFERIOR DIREITO/ESQUERDO COM FRISO

- | | |
|---------------------|---------------------|
| SP269Z.D 104x550mm | SP269Z.E 104x550mm |
| SP269D 104x650mm | SP269E 104x650mm |
| SP269B.D 104x800mm | SP269B.E 104x800mm |
| SP269D.D 104x1000mm | SP269D.E 104x1000mm |
| SP269E.D 104x1050mm | SP269E.E 104x1050mm |
| SP269F.D 104x1100mm | SP269F.E 104x1100mm |
| SP269G.D 104x1200mm | SP269G.E 104x1200mm |



CAIXA DO FUEIRO 130mm
SP083 - ch. 6,35mm - 1,980kg



ENCAIXE FUEIRO SUPERIOR
SP081.1 - ch. 3,75mm - 0,970kg

CARRETAS LINHA TECNO 5 TAMPA DE MADEIRA 2008



GRADE DO TOMBADOR SUPERIOR TECNO 5 TAMPA DE MADEIRA
GR055 650x2430mm
GR055B 800x2430mm
GR055D 1000x2430mm
GR055E 1050x2430mm
GR055F 1100x2430mm
GR055G 1200x2430mm



GRADE DO TOMBADOR INFERIOR TAMPA DE MADEIRA
GR011 650x2430mm **GR011E** 1050x2430mm
GR011B 800x2430mm **GR011F** 1100x2430mm
GR011D 1000x2430mm **GR011G** 1200x2430mm

GRADE TRASEIRA CARGA SECA TAMPA DE MADEIRA
GR011Y 500x2430mm
GR011Z 550x2430mm



GRADE LATERAL SUPERIOR BITREM TECNO 5 TAMPA DE MADEIRA
GR056 650x2212mm **GR056E** 1050x2212mm
GR056B 800x2212mm **GR056F** 1100x2212mm
GR056D 1000x2212mm **GR056G** 1200x2212mm

GRADE LATERAL SUPERIOR CARRETA TECNO 5 TAMPA DE MADEIRA
GR057 650x2965mm **GR057E** 1050x2965mm
GR057B 800x2965mm **GR057F** 1100x2965mm
GR057D 1000x2965mm **GR057G** 1200x2965mm

GRADE LATERAL SUPERIOR BITREM 7,50m TECNO 5 TAMPA DE MADEIRA
GR058 650x2430mm **GR058E** 1050x2430mm
GR058B 800x2430mm **GR058F** 1100x2430mm
GR058D 1000x2430mm **GR058G** 1200x2430mm

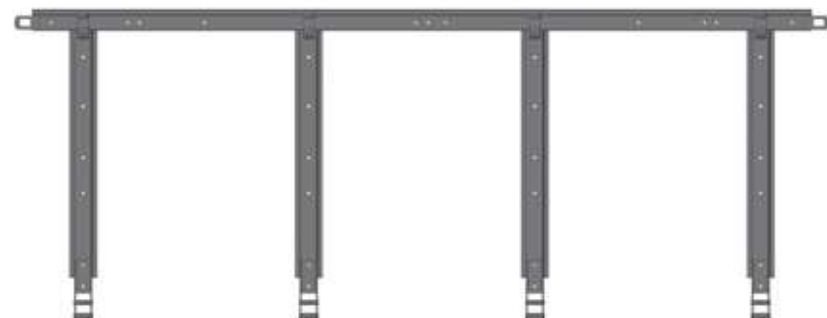

GRADE LATERAL INFERIOR BITREM TAMPA DE MADEIRA
GR013 650x2212mm **GR013E** 1050x2212mm
GR013B 800x2212mm **GR013F** 1100x2212mm
GR013D 1000x2212mm **GR013G** 1200x2212mm

GRADE LATERAL INFERIOR CARRETA TAMPA DE MADEIRA
GR016 650x2965mm **GR016E** 1050x2965mm
GR016B 800x2965mm **GR016F** 1100x2965mm
GR016D 1000x2965mm **GR016G** 1200x2965mm

GRADE LATERAL INFERIOR BITREM 7,50m TAMPA DE MADEIRA
GR054 650x2430mm **GR054E** 1050x2430mm
GR054B 800x2430mm **GR054F** 1100x2430mm
GR054D 1000x2430mm **GR054G** 1200x2430mm

GRADE LATERAL CARGA SECA TAMPA DE MADEIRA
GR016Y 500x2965mm
GR016Z 550x2965mm



CONJUNTO DO TOMBADOR INFERIOR DA CARRETA
SP294 - 6,000kg
 (02 unidades)

CARRETAS LINHA TECNO 5 TAMPA DE POLIPROPILENO 2008



GRADE DO TOMBADOR SUPERIOR

TECNO 5 TAMPA PP

- GR059** 650x2430mm
- GR059B** 800x2430mm
- GR059D** 1000x2430mm
- GR059E** 1050x2430mm
- GR059F** 1100x2430mm
- GR059G** 1200x2430mm



GRADE DO TOMBADOR INFERIOR

TECNO 5 TAMPA PP

- GR017** 650x2430mm
- GR017B** 800x2430mm
- GR017D** 1000x2430mm
- GR017E** 1050x2430mm
- GR017F** 1100x2430mm
- GR017G** 1200x2430mm

GRADE TRASEIRA

CARGA SECA TAMPA PP

- GR017Y** 500x2430mm
- GR017Z** 550x2430mm



GRADE LATERAL SUPERIOR

BITREM TECNO 5 TAMPA PP

- GR060** 650x2212mm
- GR060B** 800x2212mm
- GR060D** 1000x2212mm
- GR060E** 1050x2212mm
- GR060F** 1100x2212mm
- GR060G** 1200x2212mm

GRADE LATERAL SUPERIOR

CARRETA TECNO 5 TAMPA PP

- GR061** 650x2965mm
- GR061B** 800x2965mm
- GR061D** 1000x2965mm
- GR061E** 1050x2965mm
- GR061F** 1100x2965mm
- GR061G** 1200x2965mm

GRADE LATERAL SUPERIOR

CARRETA TECNO 5 TAMPA PP

- GR140** 650x2430mm
- GR140B** 800x2430mm
- GR140D** 1000x2430mm
- GR140E** 1050x2430mm
- GR140F** 1100x2430mm
- GR140G** 1200x2430mm

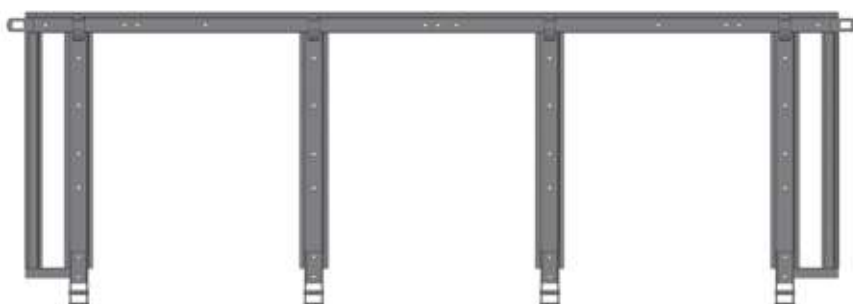

GRADE LATERAL INFERIOR

BITREM TAMPA PP

- GR019** 650x2212mm
- GR019B** 800x2212mm
- GR019D** 1000x2212mm
- GR019E** 1050x2212mm
- GR019F** 1100x2212mm
- GR019G** 1200x2212mm

GRADE LATERAL INFERIOR

CARRETA TAMPA PP

- GR010** 650x2965mm
- GR010B** 800x2965mm
- GR010D** 1000x2965mm
- GR010E** 1050x2965mm
- GR010F** 1100x2965mm
- GR010G** 1200x2965mm

GRADE LATERAL INFERIOR

CARRETA TECNO 5 TAMPA PP

- GR141** 650x2430mm
- GR141B** 800x2430mm
- GR141D** 1000x2430mm
- GR141E** 1050x2430mm
- GR141F** 1100x2430mm
- GR141G** 1200x2430mm

GRADE LATERAL

CARGA SECA TAMPA PP

- GR010Y** 500x2965mm
- GR010Z** 550x2965mm

CONJUNTO DO TOMBADOR

INFERIOR DA CARRETA

- SP294** - 6,000kg
- (02 unidades)



CARRETAS LINHA TECNO 10 TAMPA DE MADEIRA E POLIPROPILENO 2015

FRONTAIS E FUEIROS SUPERIORES E INFERIORES COM ENCOSTO CHAPA RETA E PRESILHAS DESLOCADAS



FRONTAL SUPERIOR DA CARRETA CHAPA RETA

SP498	650mm
SP498B	800mm
SP498D	1000mm



FRONTAL INFERIOR DA CARRETA CHAPA RETA

SP497Z	550mm
SP497	650mm
SP497B	800mm
SP497D	1000mm



FUEIRO LATERAL SUPERIOR DA CARRETA CHAPA RETA

SP439	104x650mm
SP439B	104x800mm
SP439D	104x1000mm

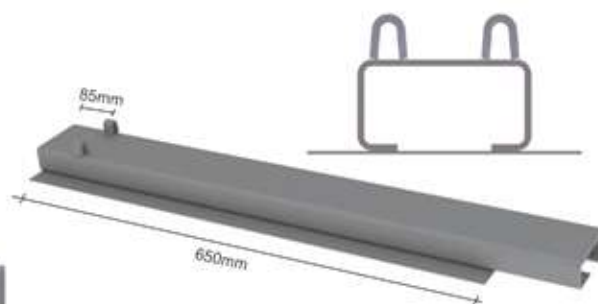

FUEIRO LATERAL INFERIOR DA CARRETA CHAPA RETA

SP441Z	104x550mm
SP441	104x650mm
SP441B	104x800mm
SP441D	104x1000mm

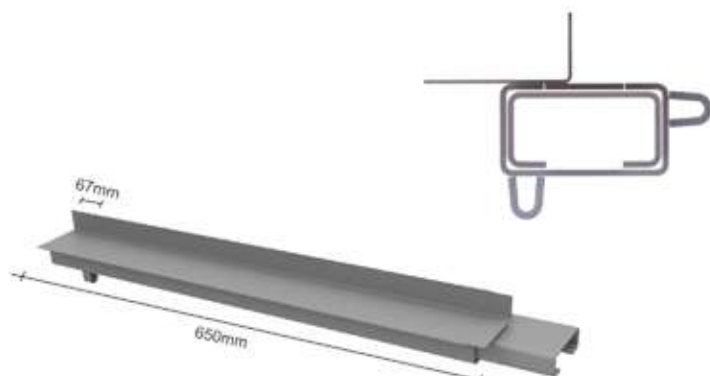

FUEIRO DE CANTO SUPERIOR DIREITO/ESQUERDO CHAPA RETA

SP440D	104x650mm	SP440E	104x650mm
SP440B.D	104x800mm	SP440B.E	104x800mm
SP440D.D	104x1000mm	SP440D.E	104x1000mm

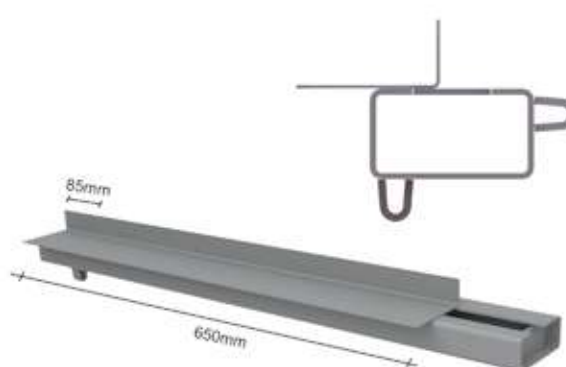

FUEIRO DE CANTO INFERIOR DIREITO/ESQUERDO CHAPA RETA

SP442Z.D	104x550mm	SP442Z.E	104x550mm
SP442D	104x650mm	SP442E	104x650mm
SP442B.D	104x800mm	SP442B.E	104x800mm
SP442D.D	104x1000mm	SP442D.E	104x1000mm

CARRETAS LINHA TECNO 10 TAMPA DE MADEIRA 2015



GRADE DO TOMBADOR SUPERIOR TECNO 10 TAMPA DE MADEIRA
GR062 650x2430mm
GR062B 800x2430mm
GR062D 1000x2430mm



GRADE DO TOMBADOR INFERIOR TECNO 10 TAMPA DE MADEIRA
GR063 650x2430mm
GR063B 800x2430mm
GR063D 1000x2430mm



GRADE LATERAL SUPERIOR BITREM TECNO 10 TAMPA DE MADEIRA
GR064 650x2212mm
GR064B 800x2212mm
GR064D 1000x2212mm

GRADE LATERAL SUPERIOR CARRETA TECNO 10 TAMPA DE MADEIRA
GR065 650x2965mm
GR065B 800x2965mm
GR065D 1000x2965mm



GRADE LATERAL SUPERIOR BITREM 7,50m TECNO 10 TAMPA DE MADEIRA
GR066 650x2430mm
GR066B 800x2430mm
GR066D 1000x2430mm

GRADE LATERAL INFERIOR BITREM TECNO 10 TAMPA DE MADEIRA
GR067 650x2212mm
GR067B 800x2212mm
GR067D 1000x2212mm

GRADE LATERAL INFERIOR CARRETA TECNO 10 TAMPA DE MADEIRA
GR068 650x2965mm
GR068B 800x2965mm
GR068D 1000x2965mm



GRADE LATERAL INFERIOR BITREM 7,50m TECNO 10 TAMPA DE MADEIRA
GR069 650x2430mm
GR069B 800x2430mm
GR069D 1000x2430mm

CONJUNTO DO TOMBADOR INFERIOR DA CARRETA
SP294 - 6.000kg
 (02 unidades)

CARRETAS TECNO 10 TAMPA DE POLIPROPILENO GRADES C/TUBO 2015



**GRADE DO TOMBADOR
SUPERIOR TAMPA DE
PP C/TUBO**

GR042 635x2430mm
GR042B 785x2430mm
GR042D 985x2430mm



**GRADE DO TOMBADOR
INFERIOR TAMPA DE
PP C/TUBO**

GR043 650x2430mm
GR043B 800x2430mm
GR043D 1000x2430mm

**GRADE TRASEIRA
CARGA SECA TAMPA
DE PP C/TUBO**

GR043Z 550x2430mm



**GRADE LATERAL
SUPERIOR BITREM
TAMPA DE PP C/TUBO**

GR044 635x2212mm
GR044B 785x2212mm
GR044D 985x2212mm

**GRADE LATERAL
SUPERIOR CARRETA
TAMPA DE PP C/TUBO**

GR046 635x2965mm
GR046B 785x2965mm
GR046D 985x2965mm

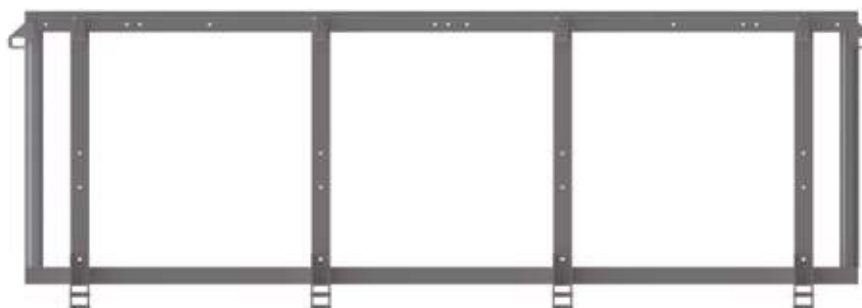

**GRADE LATERAL
INFERIOR BITREM
TAMPA DE PP C/TUBO**

GR045 650x2212mm
GR045B 800x2212mm
GR045D 1000x2212mm

**GRADE LATERAL
INFERIOR CARRETA
TAMPA DE PP C/TUBO**

GR047 650x2965mm
GR047B 800x2965mm
GR047D 1000x2965mm

**GRADE LATERAL
CARGA SECA TAMPA
DE PP C/TUBO**

GR047Z 550x2965mm



**CONJUNTO DO
TOMBADOR INFERIOR
DA CARRETA**

SP294 - 6,000kg
(02 unidades)

CARRETAS LINHA RODOFORT/GUERRA

FRONTAIS E FUEIROS COMPATÍVEIS COM A LINHA TECNO10 GUERRA



**GRADE DO TOMBADOR
SUPERIOR TAMPA
ACM RDF/GE TUBO**
GR158 650x2430mm
GR158B 800x2430mm
GR158D 1000x2430mm



**GRADE DO TOMBADOR
INFERIOR TAMPA ACM
RDF/GE TUBO**
GR159 650x2430mm
GR159B 800x2430mm
GR159D 1000x2430mm

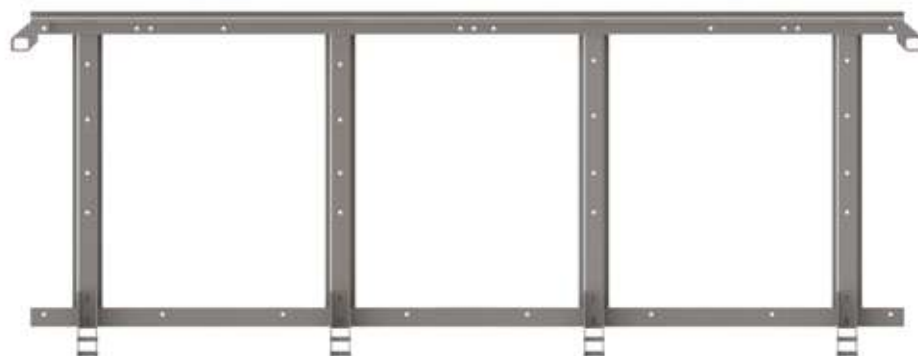

**GRADE LATERAL SUPERIOR
TAMPA DE ACM RDF/GE TUBO**
GR160 650x2212mm
GR160B 800x2212mm
GR160D 1000x2212mm



**GRADE LATERAL INFERIOR
TAMPA DE ACM RDF/GE TUBO**
GR161 650x2212mm
GR161B 800x2212mm
GR161D 1000x2212mm



**CONJUNTO DO
TOMBADOR INFERIOR
DA CARRETA**
SP294 - 6,000kg
(02 unidades)



DOBRADIÇA DO TOMBADOR INFERIOR - 167mm

SP301 - ch. 4,25mm - 0,410kg
SP301B - SEM PINTURA
(10 unidades)

DOBRADIÇA DO TOMBADOR SUPERIOR - 167mm

SP301A - ch. 4,25mm - 0,470kg
SP301AB - SEM PINTURA
(10 unidades)

DOBRADIÇA DA TAMPA CARRETA ÁGUILA/FÊNIX 2012 - 200mm

SP296 - ch. 4,25mm - 0,640kg
SP296B - SEM PINTURA
(25 unidades)

DOBRADIÇA DA TAMPA CARRETA FÊNIX 2014/TITANIUM - 173mm

SP512 - ch. 4,25mm - 0,620kg
SP512B - SEM PINTURA
(25 unidades)



GANCHO DO TOMBADOR TITANIUM - 263mm

SP797 - ch. 6,35mm - 1,220kg
SP797B - SEM PINTURA
(10 unidades)

ENGATE RÁPIDO DOBRADIÇA LINHA FÊNIX

SP467 - ch. 8,00mm - 0,230kg
largura 32mm * SEM PINTURA
(25 unidades)



TRAVA DO GANCHO DO TOMBADOR

SP408 - 0,360kg
(10 unidades)



ENGATE FÊMEA SUPERIOR/ INFERIOR LINHA FÊNIX

SP407 - ch. 4,25mm - 0,150kg
* SEM PINTURA
(25 unidades)



GANCHO DO TOMBADOR

SP300 - ch. 6,35mm - 0,920kg
(10 unidades)

RÉGUA DIANTEIRA DO PARABARRO - 590mm

SP412 - 0,560kg
(10 unidades)

RÉGUA TRASEIRA DO PARABARRO - 660mm

SP411 - 0,620kg
(10 unidades)

COLUNA SUP GRADE LN FÊNIX/TITANIUM

SP410 538mm
SP410A 588mm
SP410B 688mm
SP410C 788mm
SP410D 888mm
SP410E 938mm
SP410F 988mm
SP410G 1088mm

COLUNA INF GRADE LN FÊNIX/TITANIUM

SP409Z 425mm
SP409 525mm
SP409A 575mm
SP409B 675mm
SP409C 775mm
SP409D 875mm
SP409E 925mm
SP409F 975mm
SP409G 1075mm

VIGUETAS LINHA FÊNIX/TITANIUM

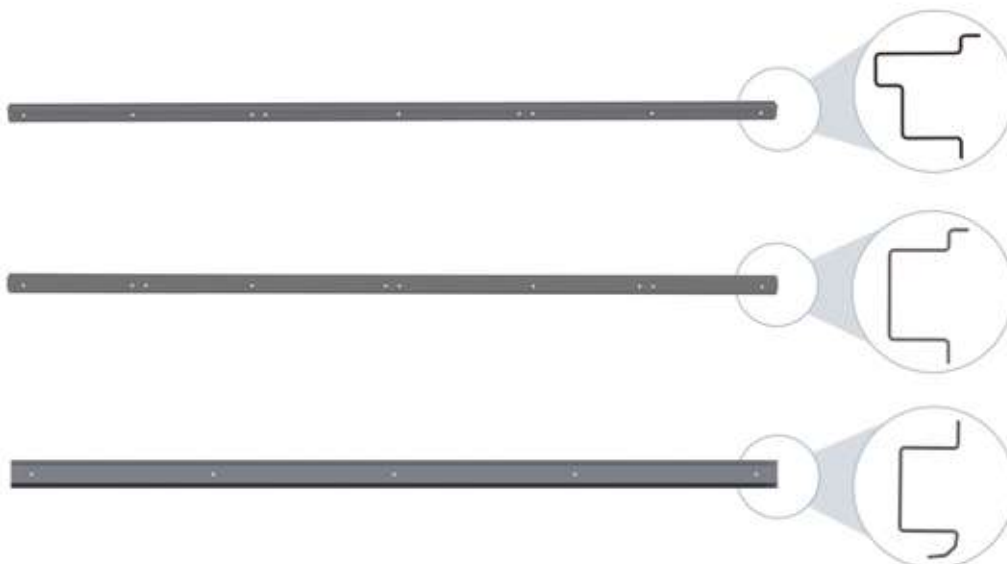

VIGUETA SUPERIOR DA TAMPA SUPERIOR



SP414 2365mm
SP414A 2445mm
SP414B 2217mm
SP414C 2865mm

VIGUETA SUPERIOR DA TAMPA INFERIOR

SP415 2365mm
SP415A 2445mm
SP415B 2217mm
SP415C 2865mm

VIGUETA INFERIOR DA TAMPA SUPERIOR/INFERIOR

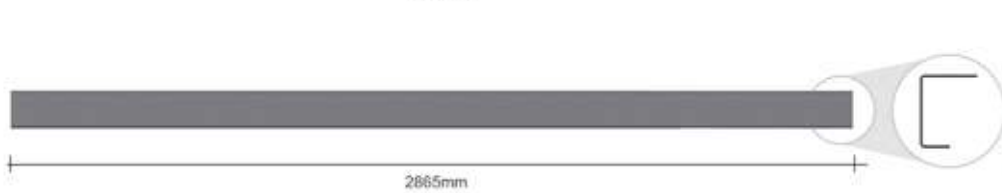
SP416 2365mm
SP416A 2445mm
SP416B 2217mm
SP416C 2865mm

 <p>2445mm</p>	<p>PERFIL DIANTEIRO DA CARRETA - 2445mm SP297 - ch. 4,25mm - 23,270kg</p>
 <p>2445mm</p>	<p>PERFIL DIANTEIRO CAR/BT FREIOS ABS - 2445mm SP297A - ch. 4,25mm - 27,260kg</p>
 <p>2445mm</p>	<p>PERFIL DIANTEIRO CAR/BT FREIOS ABS ASSOALHO DE FERRO TITANIUM - 2445mm SP786 - ch. 4,25mm - 23,900kg</p>
 <p>2445mm</p>	<p>PERFIL DIANTEIRO CAR/BT FREIOS ABS ASSOALHO DE MADEIRA TITANIUM - 2445mm SP914 - ch. 4,25mm - 28,550kg</p>
 <p>2865mm</p>	<p>PERFIL LATERAL DA CARRETA SEM FURAÇÃO SP298 - 2865mm - ch. 4,25mm - 25,230kg SP298A - 2365mm - ch. 4,25mm - 20,820kg SP298B - 2217mm - ch. 4,25mm - 19,520kg</p>
 <p>2865mm</p>	<p>PERFIL LATERAL DA CARRETA COM FURAÇÃO FÊNIX/TITANIUM SP784 - 2865mm - ch. 4,25mm - 25,230kg SP784A - 2365mm - ch. 4,25mm - 20,820kg SP784B - 2217mm - ch. 4,25mm - 19,520kg</p>
 <p>2865mm</p>	<p>PERFIL LATERAL DA CARRETA ASSOALHO DE FERRO SP787 - 2865mm - ch. 4,25mm - 23,530kg SP787A - 2365mm - ch. 4,25mm - 19,300kg SP787B - 2217mm - ch. 4,25mm - 18,160kg</p>
 <p>2445mm</p>	<p>PERFIL TRASEIRO DA CARRETA - 2445mm SP299 - ch. 4,25mm - 21,620kg</p>
 <p>2445mm</p>	<p>PERFIL TRASEIRO DA CARRETA COM FURAÇÃO - 2445mm SP785 - ch. 4,25mm - 24,710kg</p>
 <p>2445mm</p>	<p>PERFIL TRASEIRO DA CARRETA ASSOALHO DE FERRO - 2445mm SP788 - ch. 4,25mm - 20,100kg</p>

CARRETAS LINHA FÊNIX A PARTIR DE 2012 E TITANIUM



FRONTAL SUPERIOR DA CARRETA GRANELEIRA

SP417	653mm
SP417B	803mm
SP417D	1003mm
SP417E	1053mm
SP417F	1103mm
SP417G	1203mm

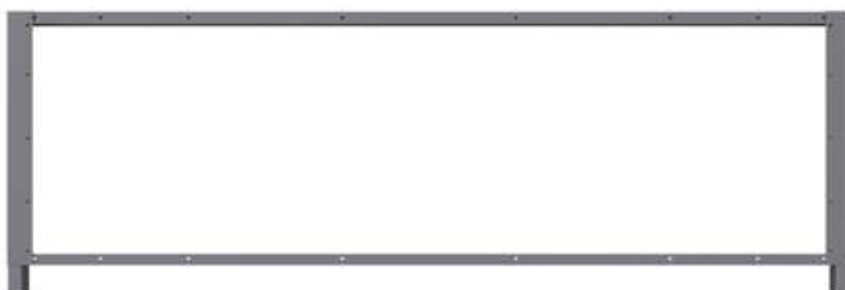

FRONTAL INFERIOR DA CARRETA GRANELEIRA

SP418Z	540mm
SP418	640mm
SP418B	790mm
SP418D	990mm
SP418E	1040mm
SP418F	1090mm
SP418G	1190mm



FUEIRO LATERAL SUPERIOR COM FRISO

SP419	97x653mm	SP419E	97x1053mm
SP419B	97x803mm	SP419F	97x1103mm
SP419D	97x1003mm	SP419G	97x1203mm

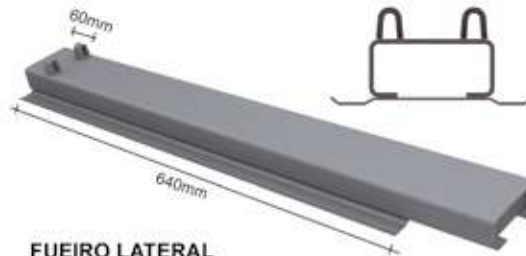

FUEIRO LATERAL INFERIOR COM FRISO

SP420Z	97x540mm	SP420E	97x1040mm
SP420	97x640mm	SP420F	97x1090mm
SP420B	97x790mm	SP420G	97x1190mm
SP420D	97x990mm		



FUEIRO DE CANTO SUPERIOR COM FRISO DIREITO/ESQUERDO

SP421D	97x653mm	SP421E	97x653mm
SP421B.D	97x803mm	SP421B.E	97x803mm
SP421D.D	97x1003mm	SP421D.E	97x1003mm
SP421E.D	97x1053mm	SP421E.E	97x1053mm
SP421F.D	97x1103mm	SP421F.E	97x1103mm
SP421G.D	97x1203mm	SP421G.E	97x1203mm



FUEIRO DE CANTO INFERIOR COM FRISO DIREITO/ESQUERDO

SP422Z.D	97x540mm	SP422Z.E	97x540mm
SP422D	97x640mm	SP422E	97x640mm
SP422B.D	97x790mm	SP422B.E	97x790mm
SP422D.D	97x990mm	SP422D.E	97x990mm
SP422E.D	97x1040mm	SP422E.E	97x1040mm
SP422F.D	97x1090mm	SP422F.E	97x1090mm
SP422G.D	97x1190mm	SP422G.E	97x1190mm



CAIXA DO FUEIRO 130mm
SP135 - ch. 6,35mm - 1,975kg



CAIXA DO FUEIRO P/CARRETA ASSOALHO DE FERRO 110mm
SP838 - ch. 6,35mm - 1,620kg



ENCAIXE DO FUEIRO SUPERIOR
SP127.3 - ch. 3,75mm - 0,970kg

GRADES P/CARRETAS LINHA FÊNIX 2012 E 2013

AS GRADES LATERAIS DOS ANOS 2012 E 2013 SÃO MONTADAS C/DOBRADIÇA DE 200mm DE COMPRIMENTO E AS GRADES DO TOMBADOR C/DOBRADIÇA DE 167mm DE COMPRIMENTO

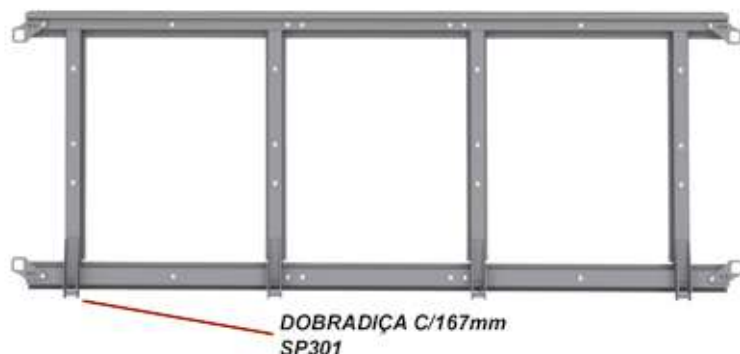

GRADE DO TOMBADOR SUPERIOR FÊNIX

GR029	653x2445mm
GR029B	803x2445mm
GR029D	1003x2445mm

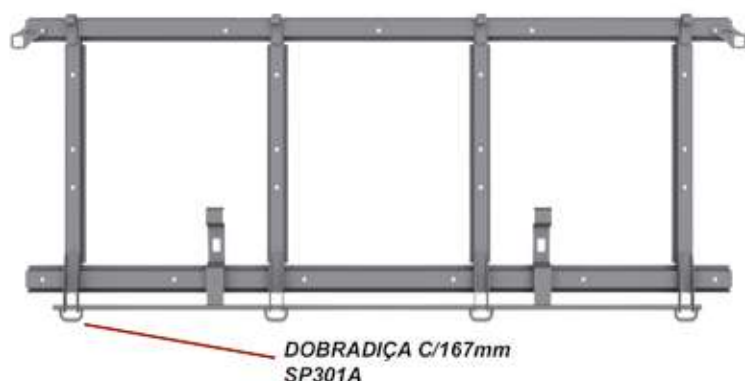

GRADE DO TOMBADOR INFERIOR FÊNIX

GR030	640x2445mm
GR030B	790x2445mm
GR030D	990x2445mm

GRADE TRASEIRA CARGA SECA FÊNIX

GR030Z	540x2445mm
--------	------------

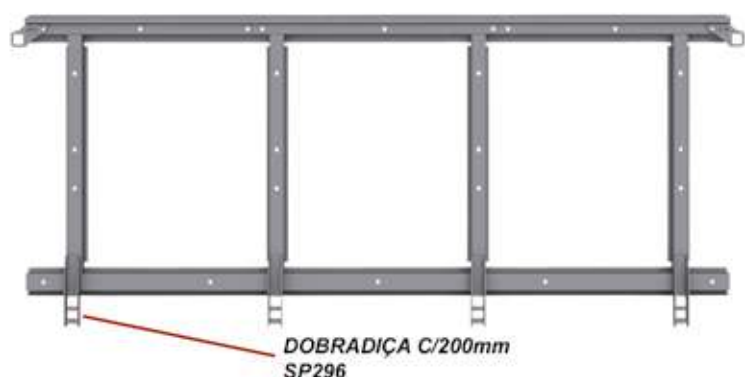

GRADE LATERAL SUPERIOR BITREM FÊNIX 2012/2013

GR031	653x2217mm
GR031B	803x2217mm
GR031D	1003x2217mm

GRADE LATERAL SUPERIOR CARRETA FÊNIX 2012/2013

GR033	653x2865mm
GR033B	803x2865mm
GR033D	1003x2865mm

GRADE LATERAL SUPERIOR CARRETA FÊNIX 2012/2013

GR032	653x2365mm
GR032B	803x2365mm
GR032D	1003x2365mm

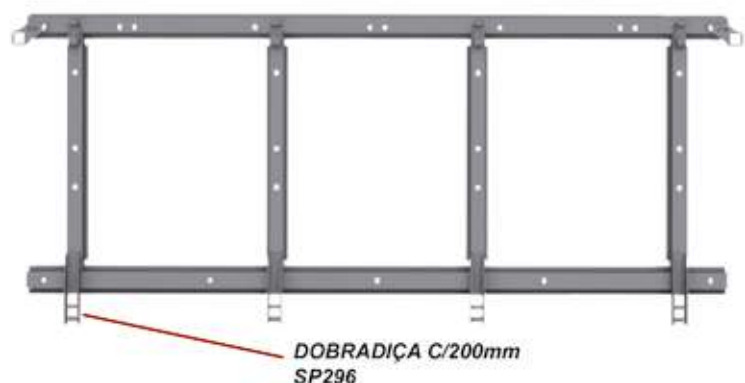

GRADE LATERAL INFERIOR BITREM FÊNIX 2012/2013

GR034	640x2217mm
GR034B	790x2217mm
GR034D	990x2217mm

GRADE LATERAL INFERIOR CARRETA FÊNIX 2012/2013

GR036	640x2865mm
GR036B	790x2865mm
GR036D	990x2865mm

GRADE LATERAL INFERIOR CARRETA FÊNIX 2012/2013

GR035	640x2365mm
GR035B	790x2365mm
GR035D	990x2365mm

GRADE LATERAL CARGA SECA FÊNIX 2012/2013

GR035Z	540x2365mm
--------	------------



CONJUNTO DO TOMBADOR INFERIOR DA CARRETA
SP423 - 7,300kg
(02 unidades)

GRADES P/CARRETAS LINHA FÊNIX A PARTIR DE 2014

A PARTIR DO ANO DE 2014 AS GRADES LATERAIS SUPERIORES E INFERIORES DA LINHA FÊNIX, SÃO MONTADAS C/DOBRADIÇA DE 173mm DE COMPRIMENTO. AS GRADES DO TOMBADOR PERMANECEM IGUAIS.



DOBRADIÇA C/167mm
SP301

GRADE DO TOMBADOR SUPERIOR FÊNIX

GR029	653x2445mm
GR029B	803x2445mm
GR029D	1003x2445mm
GR029E	1053x2445mm
GR029F	1103x2445mm
GR029G	1203x2445mm

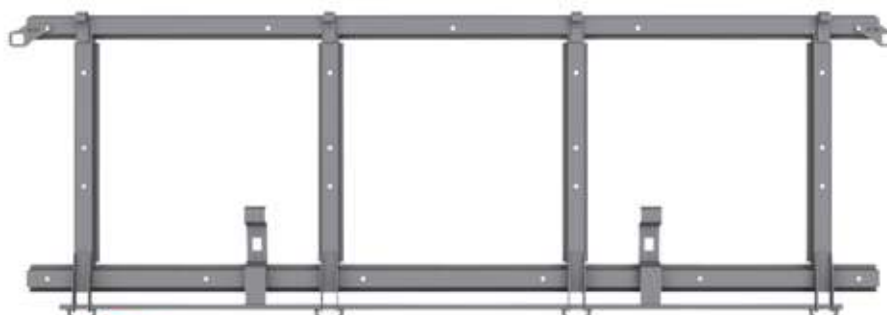

DOBRADIÇA C/167mm
SP301A

GRADE DO TOMBADOR INFERIOR FÊNIX

GR030	640x2445mm
GR030B	790x2445mm
GR030D	990x2445mm
GR030E	1040x2445mm
GR030F	1090x2445mm
GR030G	1190x2445mm

GRADE TRASEIRA CARGA SECA FÊNIX

GR030Z	540x2445mm
--------	------------

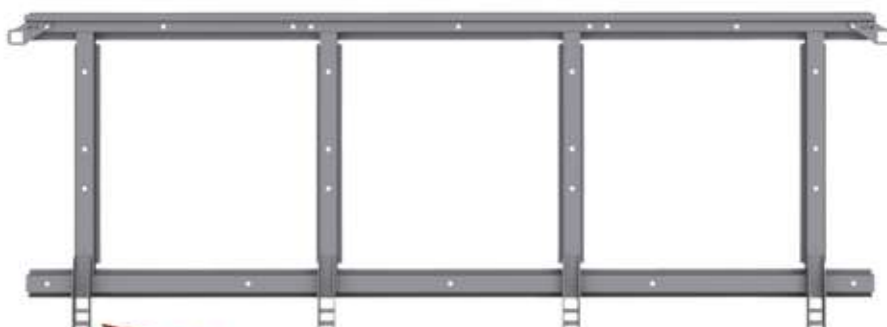

DOBRADIÇA C/173mm
SP512

GRADE LATERAL SUPERIOR BITREM FÊNIX 2014

GR078	653x2217mm	GR078E	1053x2217mm
GR078B	803x2217mm	GR078F	1103x2217mm
GR078D	1003x2217mm	GR078G	1203x2217mm

GRADE LATERAL SUPERIOR CARRETA FÊNIX 2014

GR079	653x2365mm	GR079E	1053x2365mm
GR079B	803x2365mm	GR079F	1103x2365mm
GR079D	1003x2365mm	GR079G	1203x2365mm

GRADE LATERAL SUPERIOR CARRETA FÊNIX 2014

GR080	653x2865mm	GR080E	1053x2865mm
GR080B	803x2865mm	GR080F	1103x2865mm
GR080D	1003x2865mm	GR080G	1203x2865mm

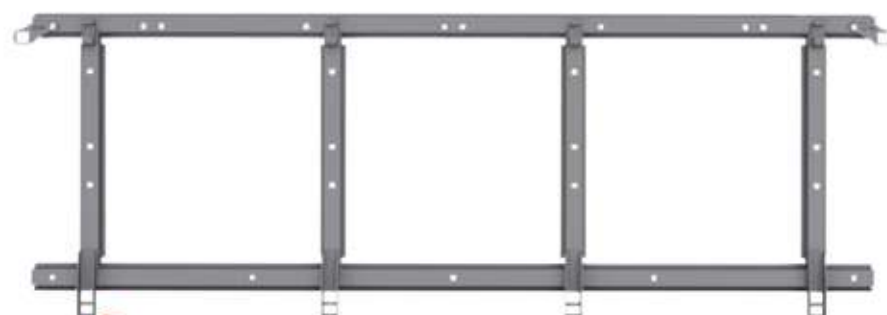

DOBRADIÇA C/173mm
SP512

GRADE LATERAL INFERIOR BITREM FÊNIX 2014

GR081	640x2217mm	GR081E	1040x2217mm
GR081B	790x2217mm	GR081F	1090x2217mm
GR081D	990x2217mm	GR081G	1190x2217mm

GRADE LATERAL INFERIOR CARRETA FÊNIX 2014

GR082	640x2365mm	GR082E	1040x2365mm
GR082B	790x2365mm	GR082F	1090x2365mm
GR082D	990x2365mm	GR082G	1190x2365mm

GRADE LATERAL INFERIOR CARRETA FÊNIX 2014

GR083	640x2865mm	GR083E	1040x2865mm
GR083B	790x2865mm	GR083F	1090x2865mm
GR083D	990x2865mm	GR083G	1190x2865mm

GRADE LATERAL CARGA SECA FÊNIX 2014

GR082Z	540x2365mm
--------	------------

CONJUNTO DO TOMBADOR INFERIOR DA CARRETA

SP423	- 7,300kg (02 unidades)
-------	----------------------------

GRADES P/CARRETAS LINHA TITANIUM 2020

AS GRADES PARA CARRETAS DESTA LINHA EM SUA VERSÃO ORIGINAL SÃO MONTADAS COM DOBRADIÇAS DE FERRO FUNDIDO. A METAL C DESENVOLVEU GRADES QUE ATENDEM ESSA LINHA, PORÉM COM DOBRADIÇAS DE AÇO CARBONO.

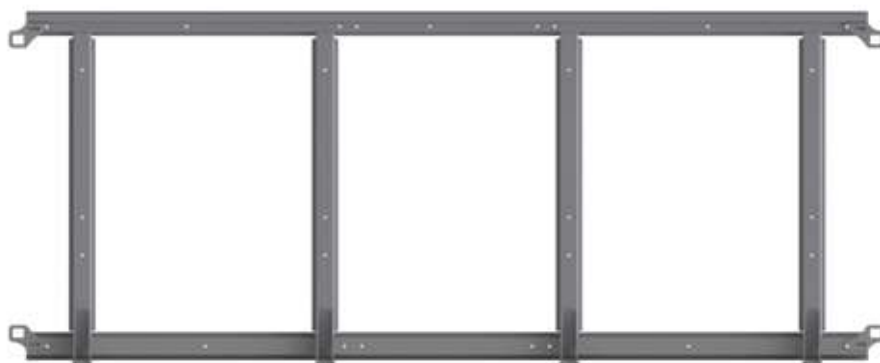

GRADE DO TOMBADOR SUPERIOR TITANIUM

GR123 653x2445mm
GR123B 803x2445mm
GR123D 1003x2445mm



GRADE DO TOMBADOR INFERIOR TITANIUM

GR124 640x2445mm
GR124B 790x2445mm
GR124D 990x2445mm



GRADE TRASEIRA CARGA SECA TITANIUM

GR124Z 540x2445mm



GRADE LATERAL SUPERIOR BITREM 7.10m TITANIUM

GR125 653x2217mm
GR125B 803x2217mm
GR125D 1003x2217mm

GRADE LATERAL SUPERIOR CARRETA 5 TAMPAS TITANIUM

GR126 653x2365mm
GR126B 803x2365mm
GR126D 1003x2365mm

GRADE LATERAL SUPERIOR CARRETA TITANIUM

GR127 653x2865mm
GR127B 803x2865mm
GR127D 1003x2865mm



GRADE LATERAL INFERIOR BITREM 7.10m TITANIUM

GR128 640x2217mm
GR128B 790x2217mm
GR128D 990x2217mm

GRADE LATERAL INFERIOR CARRETA 5 TAMPAS TITANIUM

GR129 640x2365mm
GR129B 790x2365mm
GR129D 990x2365mm

GRADE LATERAL INFERIOR CARRETA TITANIUM

GR130 640x2865mm
GR130B 790x2865mm
GR130D 990x2865mm

GRADE LATERAL CARGA SECA TITANIUM
GR130Z 540x2865mm

CONJUNTO DO TOMBADOR INFERIOR DA CARRETA TITANIUM

SP801 - 10,180kg
 (02 unidades)

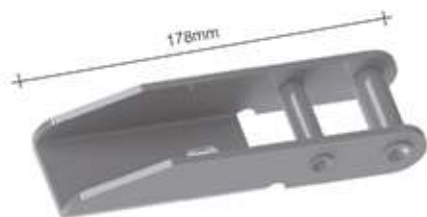

DOBRADIÇA DA TAMPA - 178mm
SP427 - ch. 4,25mm - 0,550kg
SP427B - SEM PINTURA
 (25 unidades)

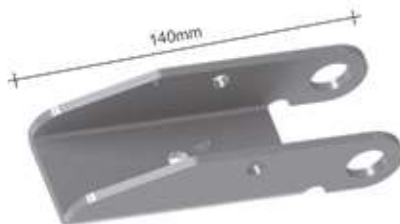

DOBRADIÇA TOMBADOR INFERIOR - 140mm
SP428 - ch. 4,25mm - 0,290kg
SP428B - SEM PINTURA
 (10 unidades)

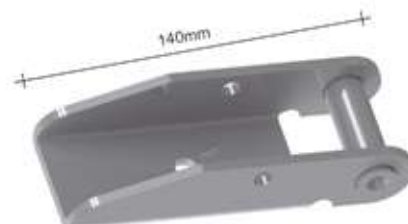

DOBRADIÇA TOMBADOR SUPERIOR - 140mm
SP428A - ch. 4,25mm - 0,320kg
SP428AB - SEM PINTURA
 (10 unidades)



ENGATE RÁPIDO DOBRADIÇA - 32mm
SP426 - ch. 8,00mm - 0,230kg
 *SEM PINTURA
 (25 unidades)

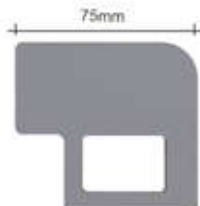

ENGATE FÊMEA TAMPA SUPERIOR/INFERIOR - 75mm
SP320 - ch. 6,35mm - 0,180kg
 *SEM PINTURA
 (25 unidades)



ENGATE FÊMEA SUPERIOR/INFERIOR HORIZON - ch. 6,35mm - 0,123kg
SP516D - DIREITO
SP516E - ESQUERDO
 *SEM PINTURA
 (25 unidades)



RÉGUA DE FIXAÇÃO DO PARABARRO - 590mm
SP328 - 0,470kg
 (10 unidades)



COLUNA DA GRADE SUPERIOR HORIZON

SP518 640mm
SP518B 690mm
SP518C 790mm
SP518D 890mm

COLUNA DA GRADE INFERIOR HORIZON

SP517Z 435mm
SP517 600mm
SP517B 700mm
SP517C 800mm
SP517D 900mm



COLUNA DA GRADE SUPERIOR/INFERIOR ECO+

SP771Z 387mm
SP771 537mm
SP771B 687mm
SP771C 787mm
SP771D 887mm

VIGUETAS LINHA HORIZON



VIGUETA SUPERIOR DA TAMPA SUPERIOR

SP519 2970mm **SP519B** 2230mm
SP519A 2430mm **SP519C** 2590mm



VIGUETA SUPERIOR DA TAMPA INFERIOR

SP520 2970mm **SP520B** 2230mm
SP520A 2430mm **SP520C** 2590mm



VIGUETA INFERIOR DA TAMPA SUPERIOR/INFERIOR

SP521 2970mm **SP521B** 2230mm
SP521A 2430mm **SP521C** 2590mm

VIGUETAS LINHA ECO+



VIGUETA SUPERIOR DA TAMPA SUPERIOR ECO+
SP733 2970mm **SP733B** 2230mm
SP733A 2430mm **SP733C** 2590mm



VIGUETA SUPERIOR DA TAMPA INFERIOR ECO+
SP734 2970mm **SP734B** 2230mm
SP734A 2430mm **SP734C** 2590mm



VIGUETA INFERIOR DA TAMPA SUPERIOR ECO+
SP735 2970mm **SP735B** 2230mm
SP735A 2430mm **SP735C** 2590mm



VIGUETA INFERIOR DA TAMPA INFERIOR ECO+
SP736 2970mm **SP736B** 2230mm
SP736A 2430mm **SP736C** 2590mm

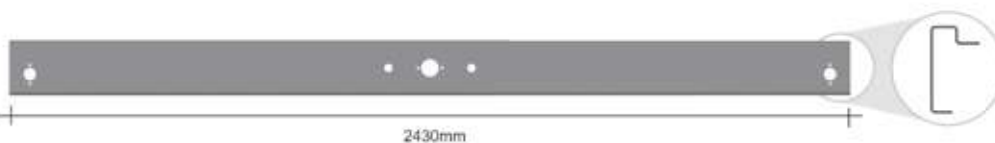

PERFIL DIANTEIRO DA CARRETA - 2430mm
SP322 - ch. 4,25mm - 24,000kg



PERFIL DIANTEIRO DA CARRETA HORIZON E ECO+ - 2430mm
SP522 - ch. 4,25mm - 19,600kg

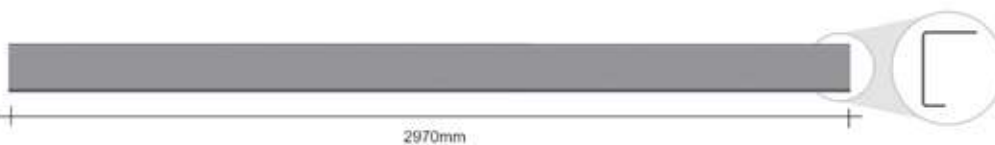

PERFIL LATERAL DA CARRETA SEM FURAÇÃO
SP323 - 2970mm - ch. 4,25mm - 25,000kg
SP323A - 2230mm - ch. 4,25mm - 18,800kg
SP323B - 2590mm - ch. 4,25mm - 21,840kg

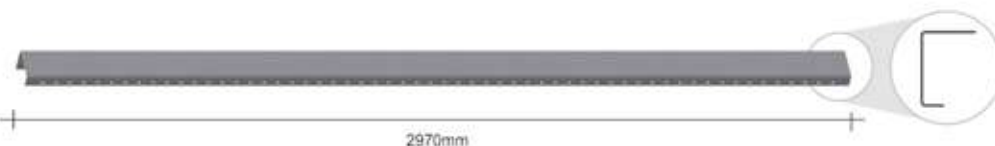

PERFIL LATERAL DA CARRETA COM FURAÇÃO
SP794 - 2970mm - ch. 4,25mm - 25,000kg
SP794A - 2230mm - ch. 4,25mm - 18,800kg
SP794B - 2590mm - ch. 4,25mm - 21,840kg

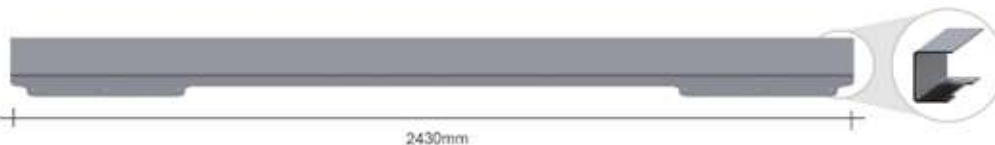

PERFIL TRASEIRO DA CARRETA - 2430mm
SP324 - ch. 4,25mm - 24,000kg



PERFIL TRASEIRO LINHA HORIZON - 2430mm
SP523 - ch. 4,25mm - 22,000kg

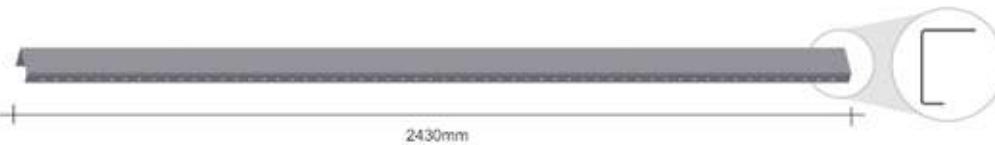

PERFIL TRASEIRO LINHA ECO+ - 2430mm
SP795 - ch. 4,25mm - 24,620kg

CARRETAS LINHA HORIZON 2013 A 2017

OS FUEIROS DESTA LINHA POSSUEM O ENCOSTO COM CHAPA RETA.



FRONTAL SUPERIOR DA CARRETA GRANELEIRA

- SP524B 800mm
- SP524C 900mm
- SP524D 1000mm



FRONTAL INFERIOR DA CARRETA GRANELEIRA

- SP525Z 530mm
- SP525B 800mm
- SP525C 900mm
- SP525D 1000mm

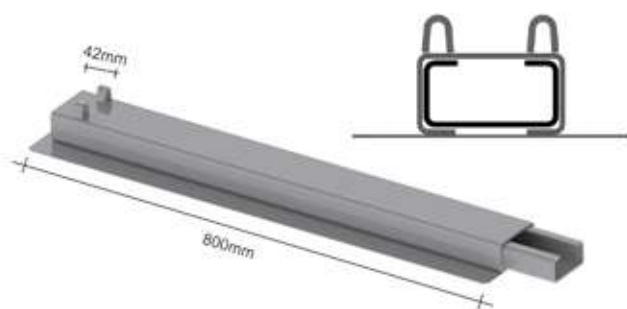

FUEIRO LATERAL SUPERIOR CHAPA RETA

- SP526B 96x800mm
- SP526C 96x900mm
- SP526D 96x1000mm

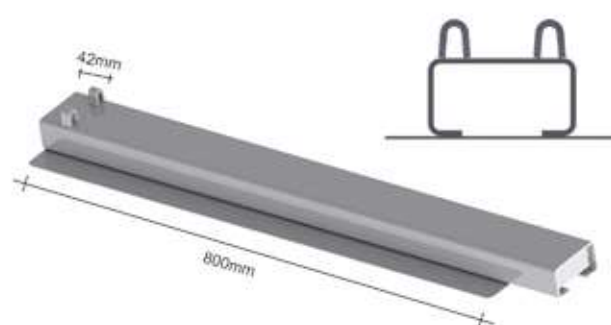

FUEIRO LATERAL INFERIOR CHAPA RETA

- SP527Z 96x530mm
- SP527B 96x800mm
- SP527C 96x900mm
- SP527D 96x1000mm

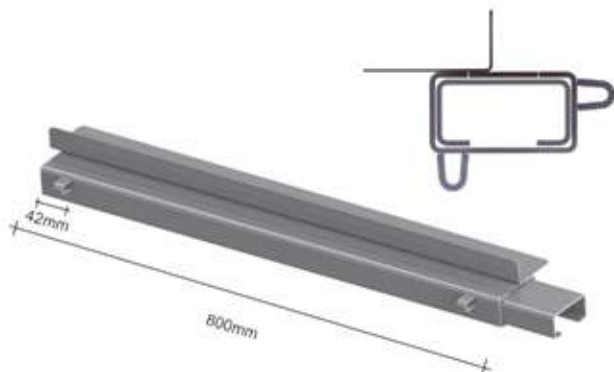

FUEIRO DE CANTO SUPERIOR DIREITO/ESQUERDO CHAPA RETA

- | | |
|--------------------|--------------------|
| SP528B.D 96x800mm | SP528B.E 96x800mm |
| SP528C.D 96x900mm | SP528C.E 96x900mm |
| SP528D.D 96x1000mm | SP528D.E 96x1000mm |

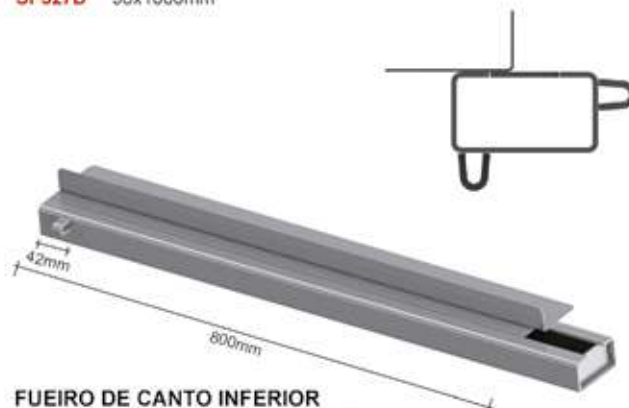

FUEIRO DE CANTO INFERIOR DIREITO/ESQUERDO CHAPA RETA

- | | |
|--------------------|--------------------|
| SP529Z.D 96x530mm | SP529Z.E 96x530mm |
| SP529B.D 96x800mm | SP529B.E 96x800mm |
| SP529C.D 96x900mm | SP529C.E 96x900mm |
| SP529D.D 96x1000mm | SP529D.E 96x1000mm |

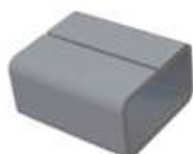

CAIXA DO FUEIRO 130mm
SP231 - ch. 6,35mm - 2,000kg

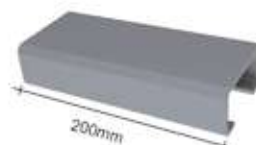

ENCAIXE DO FUEIRO SUPERIOR
SP229.1 - ch. 3,75mm - 1,240kg

CARRETAS LINHA HORIZON 2013 A 2017



GRADE DO TOMBADOR SUPERIOR HORIZON

GR084B 800x2430mm
GR084C 900x2430mm
GR084D 1000x2430mm



GRADE DO TOMBADOR INFERIOR HORIZON

GR085B 800x2430mm
GR085C 900x2430mm
GR085D 1000x2430mm



GRADE TRASEIRA CARGA SECA HORIZON

GR085Z 530x2430mm

GRADE LATERAL SUPERIOR BITREM HORIZON

GR086B 800x2230mm
GR086C 900x2230mm
GR086D 1000x2230mm

GRADE LATERAL SUPERIOR CARRETA HORIZON

GR087B 800x2970mm
GR087C 900x2970mm
GR087D 1000x2970mm

GRADE LATERAL SUPERIOR CARRETA 11,50m HORIZON

GR088B 800x2590mm
GR088C 900x2590mm
GR088D 1000x2590mm

GRADE LATERAL SUPERIOR CARRETA HORIZON

GR089B 800x2430mm
GR089C 900x2430mm
GR089D 1000x2430mm



GRADE LATERAL INFERIOR BITREM HORIZON

GR090B 800x2230mm
GR090C 900x2230mm
GR090D 1000x2230mm

GRADE LATERAL INFERIOR CARRETA HORIZON

GR091B 800x2970mm
GR091C 900x2970mm
GR091D 1000x2970mm

GRADE LATERAL INFERIOR CARRETA 11,50m HORIZON

GR092B 800x2590mm
GR092C 900x2590mm
GR092D 1000x2590mm

GRADE LATERAL CARGA SECA HORIZON

GR091Z 530x2970mm

GRADE LATERAL INFERIOR CARRETA HORIZON

GR093B 800x2430mm
GR093C 900x2430mm
GR093D 1000x2430mm



CONJUNTO DO TOMBADOR INFERIOR DA CARRETA

SP430 - 7,300kg
 (02 unidades)

CARRETAS LINHA ECO+ 2018

OS FUEIROS DESTA LINHA POSSUEM O ENCOSTO COM FRISO.



FRONTAL SUPERIOR DA CARRETA GRANELEIRA ECO+

SP796B 800mm
SP796C 900mm
SP796D 1000mm



FRONTAL INFERIOR DA CARRETA GRANELEIRA ECO+

SP790Z 550mm
SP790B 800mm
SP790C 900mm
SP790D 1000mm

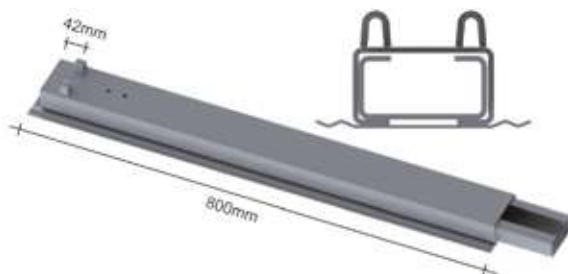

FUEIRO LATERAL SUPERIOR COM FRISO ECO+

SP798B 96x800mm
SP798C 96x900mm
SP798D 96x1000mm

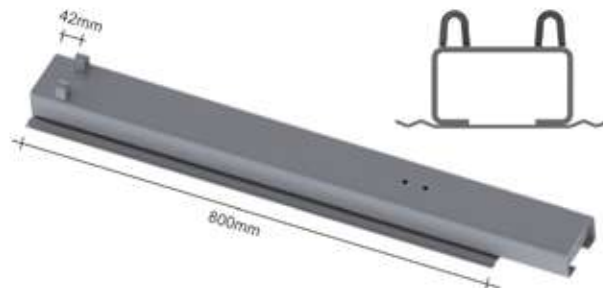

FUEIRO LATERAL INFERIOR COM FRISO ECO+

SP791Z 96x550mm
SP791B 96x800mm
SP791C 96x900mm
SP791D 96x1000mm



FUEIRO DE CANTO SUPERIOR DIREITO/ESQUERDO COM FRISO ECO+

SP800B.D 96x800mm **SP800B.E** 96x800mm
SP800C.D 96x900mm **SP800C.E** 96x900mm
SP800D.D 96x1000mm **SP800D.E** 96x1000mm

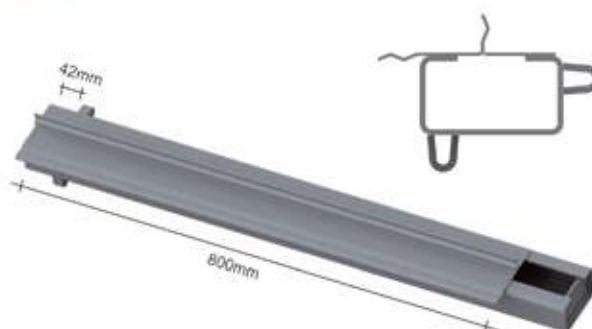

FUEIRO DE CANTO INFERIOR DIREITO/ESQUERDO COM FRISO ECO+

SP792Z.D 96x550mm **SP792Z.E** 96x550mm
SP792B.D 96x800mm **SP792B.E** 96x800mm
SP792C.D 96x900mm **SP792C.E** 96x900mm
SP792D.D 96x1000mm **SP792D.E** 96x1000mm



CAIXA DO FUEIRO 130mm
SP231 - ch. 6,35mm - 2,000kg



ENCAIXE DO FUEIRO SUPERIOR
SP229.1 - ch. 3,75mm - 1,240kg

CARRETAS LINHA ECO+ 2018



GRADE DO TOMBADOR SUPERIOR ECO+

- GR116B 800x2430mm
- GR116C 900x2430mm
- GR116D 1000x2430mm



GRADE DO TOMBADOR INFERIOR ECO+

- GR115B 800x2430mm
- GR115C 900x2430mm
- GR115D 1000x2430mm



GRADE LATERAL SUPERIOR BITREM ECO+

- GR117B 800x2230mm
- GR117C 900x2230mm
- GR117D 1000x2230mm

GRADE LATERAL SUPERIOR CARRETA ECO+

- GR113B 800x2970mm
- GR113C 900x2970mm
- GR113D 1000x2970mm

GRADE LATERAL SUPERIOR CARRETA 11,50m ECO+

- GR118B 800x2590mm
- GR118C 900x2590mm
- GR118D 1000x2590mm

GRADE LATERAL SUPERIOR CARRETA ECO+

- GR119B 800x2430mm
- GR119C 900x2430mm
- GR119D 1000x2430mm



GRADE LATERAL INFERIOR BITREM ECO+

- GR120B 800x2230mm
- GR120C 900x2230mm
- GR120D 1000x2230mm

GRADE LATERAL INFERIOR CARRETA ECO+

- GR114B 800x2970mm
- GR114C 900x2970mm
- GR114D 1000x2970mm

GRADE LATERAL INFERIOR CARRETA 11,50m ECO+

- GR121B 800x2590mm
- GR121C 900x2590mm
- GR121D 1000x2590mm

GRADE LATERAL CARGA SECA ECO+

- GR114Z 550x2970mm

GRADE LATERAL INFERIOR CARRETA ECO+

- GR122B 800x2430mm
- GR122C 900x2430mm
- GR122D 1000x2430mm



CONJUNTO DO TOMBADOR INFERIOR DA CARRETA

- SP430 - 7.300kg
- (02 unidades)



DOBRADIÇA DA TAMP - 183mm
SP513 - ch. 4,25mm - 0,560kg
SP513B - *SEM PINTURA
 (25 unidades)



DOBRADIÇA TOMBADOR INFERIOR - 183mm
SP772 - ch. 4,25mm - 0,490kg
SP772B - *SEM PINTURA
 (10 unidades)



DOBRADIÇA TOMBADOR SUPERIOR - 183mm
SP773 - ch. 4,25mm - 0,530kg
SP773B - *SEM PINTURA
 (10 unidades)



ENGATE FÊMEA SUPERIOR 205mm
SP386 - ch. 6,35mm - 0,360kg
 *SEM PINTURA
 (10 unidades)



ENGATE FÊMEA INFERIOR 200mm
SP303 - ch. 6,35mm - 0,240kg
 (10 unidades)



ENGATE FÊMEA DA TAMP SUPERIOR/INFERIOR 160mm
SP761 - ch. 6,35mm - 0,290kg
 *SEM PINTURA
 (10 unidades)



GANCHO DO TOMBADOR - 324mm
SP793 - ch. 6,35mm - 0,960kg
 (04 unidades)



COLUNA DA GRADE SUPERIOR/INFERIOR
SP307 540mm
SP307A 590mm
SP307B 690mm
SP307C 790mm
SP307D 890mm



COLUNA DA GRADE SUPERIOR/INFERIOR 2016
SP762Z 442mm
SP762 542mm
SP762A 592mm
SP762B 692mm
SP762C 792mm
SP762D 892mm



SUPORTE DO ESTEPE PARA CARRETA FACCHINI 2016
SP805 - ch. 4,25mm - 52,830kg
 * acompanha parafusos









BASE INFERIOR SUPORTE ESTEPE
SP805.1 - ch. 4,25mm - 9,580kg

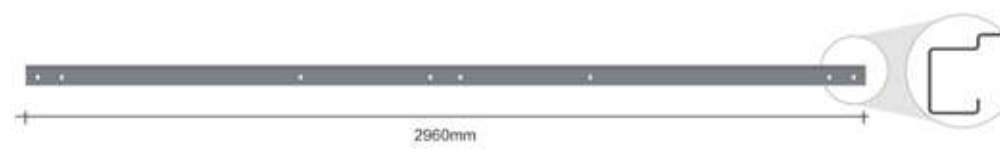
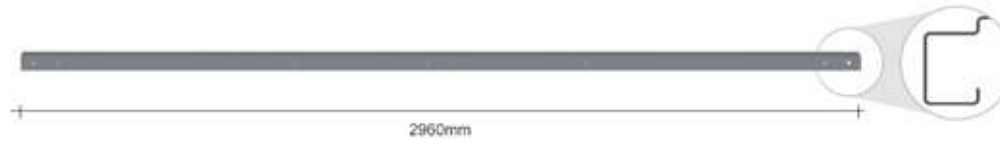
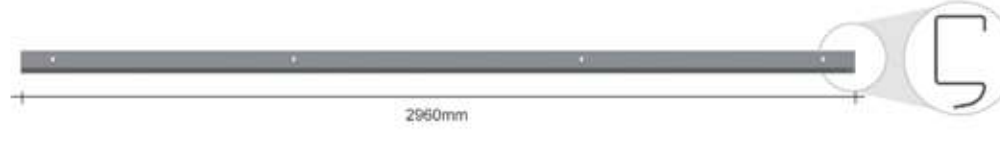
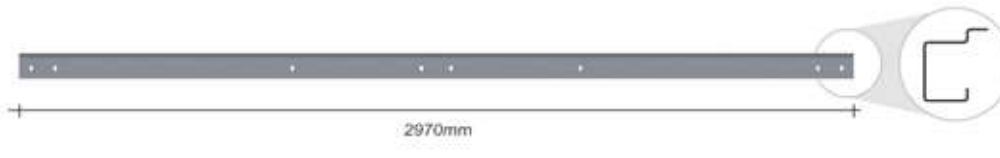

PERFIL DE APOIO DO PNEU - 1700mm
SP805.2 - ch. 4,25mm - 9,310kg

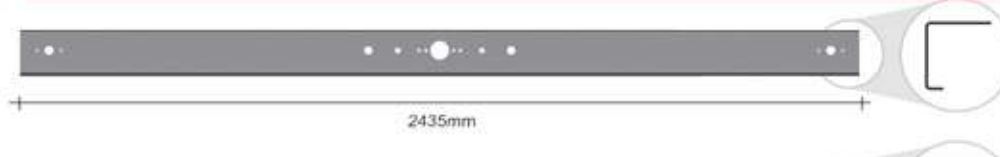

KIT FIXAÇÃO SUPORTE ESTEPE
SP805.3D - ch. 4,25mm - 3,500kg
SP805.3E - ch. 4,25mm - 3,500kg
 Parafuso sext. M12x80mm ZB c/porca (02 und.)
 Parafuso sext. M8x20mm ZB c/porca (02 und.)

 <p>2960mm</p>	<p>VIGUETA SUPERIOR DA TAMPA SUPERIOR DE MADEIRA SP309 2960mm SP309A 2430mm SP309B 2220mm</p>
 <p>2960mm</p>	<p>VIGUETA SUPERIOR DA TAMPA INFERIOR DE MADEIRA SP310 2960mm SP310A 2430mm SP310B 2220mm</p>
 <p>2960mm</p>	<p>VIGUETA INFERIOR DA TAMPA SUPERIOR/INFERIOR MADEIRA SP311 2960mm SP311A 2430mm SP311B 2220mm</p>
 <p>2970mm</p>	<p>VIGUETA SUPERIOR DA TAMPA SUPERIOR 2016 SP774 2970mm SP774A 2430mm SP774C 2735mm SP774B 2535mm SP774D 2190mm</p>
 <p>2970mm</p>	<p>VIGUETA SUPERIOR DA TAMPA INFERIOR 2016 SP775 2970mm SP775A 2430mm SP775C 2735mm SP775B 2535mm SP775D 2190mm</p>
 <p>2970mm</p>	<p>VIGUETA INFERIOR DA TAMPA SUPERIOR/INFERIOR 2016 SP776 2970mm SP776C 2735mm SP776A 2430mm SP776D 2190mm SP776B 2535mm</p>
 <p>2435mm</p>	<p>PERFIL DIANTEIRO DA CARRETA - 2435mm SP304 - ch. 4,25mm - 26,820kg</p>
 <p>2435mm</p>	<p>PERFIL DIANTEIRO DA CARRETA 2016 FREIOS ABS - 2435mm SP802 - ch. 4,25mm - 23,180kg</p>
 <p>2970mm</p>	<p>PERFIL LATERAL DA CARRETA SP305 - 2970mm - ch. 4,25mm - 28,420kg SP305A - 2730mm - ch. 4,25mm - 26,450kg SP305B - 2190mm - ch. 4,25mm - 21,220kg SP305C - 2535mm - ch. 4,25mm - 24,600kg SP305D - 2330mm - ch. 4,25mm - 23,600kg</p>
 <p>2970mm</p>	<p>PERFIL LATERAL DA CARRETA 2016 COM FURAÇÃO SP759 - 2970mm - ch. 4,25mm - 27,250kg SP759A - 2730mm - ch. 4,25mm - 25,000kg SP759B - 2190mm - ch. 4,25mm - 20,000kg SP759C - 2535mm - ch. 4,25mm - 23,300kg</p>
 <p>2435mm</p>	<p>PERFIL TRASEIRO DA CARRETA SEM FURAÇÃO - 2435mm SP306 - ch. 4,25mm - 23,600kg</p>
<p>2435mm</p>	<p>PERFIL TRASEIRO DA CARRETA 2016 COM FURAÇÃO - 2435mm SP804 - ch. 4,25mm - 23,180kg</p>

CARRETAS A PARTIR DE 2016

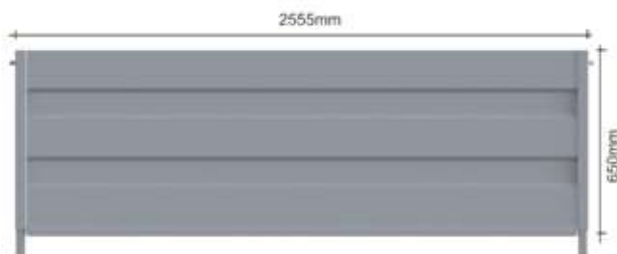

FRONTAL SUPERIOR DA CARRETA GRANELEIRA

SP433	650mm
SP433A	700mm
SP433B	800mm
SP433C	900mm
SP433D	1000mm

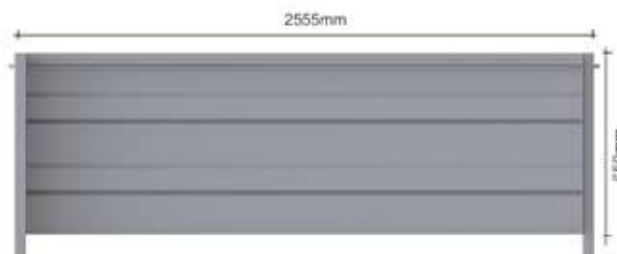

FRONTAL INFERIOR DA CARRETA GRANELEIRA

SP434Z	550mm
SP434	650mm
SP434A	700mm
SP434B	800mm
SP434C	900mm
SP434D	1000mm

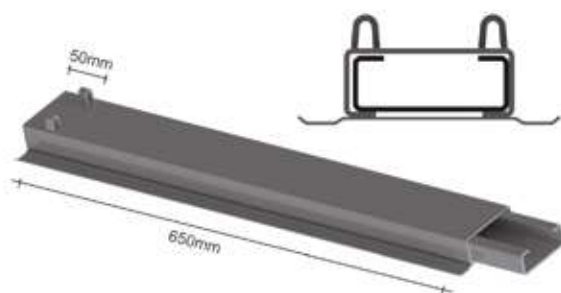

FUEIRO LATERAL SUPERIOR

SP246	124x650mm
SP246A	124x700mm
SP246B	124x800mm
SP246C	124x900mm
SP246D	124x1000mm

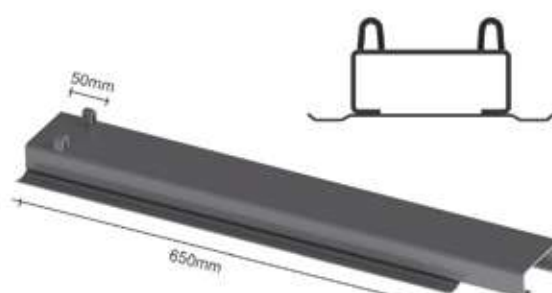

FUEIRO LATERAL INFERIOR

SP247Z	124x550mm
SP247	124x650mm
SP247A	124x700mm
SP247B	124x800mm
SP247C	124x900mm
SP247D	124x1000mm



FUEIRO DE CANTO SUPERIOR DIREITO/ESQUERDO

SP248D	124x650mm	SP248E	124x650mm
SP248A.D	124x700mm	SP248A.E	124x700mm
SP248B.D	124x800mm	SP248B.E	124x800mm
SP248C.D	124x900mm	SP248C.E	124x900mm
SP248D.D	124x1000mm	SP248D.E	124x1000mm

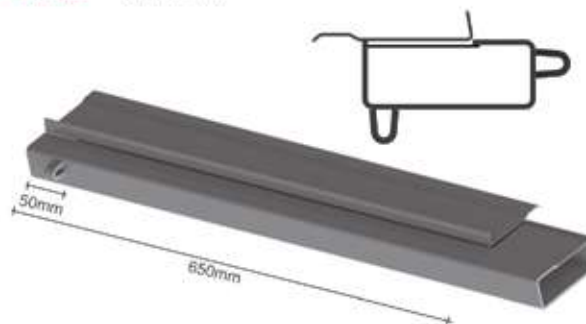

FUEIRO DE CANTO INFERIOR DIREITO/ESQUERDO

SP249Z.D	124x550mm	SP249Z.E	124x550mm
SP249D	124x650mm	SP249E	124x650mm
SP249A.D	124x700mm	SP249A.E	124x700mm
SP249B.D	124x800mm	SP249B.E	124x800mm
SP249C.D	124x900mm	SP249C.E	124x900mm
SP249D.D	124x1000mm	SP249D.E	124x1000mm



CAIXA DO FUEIRO 130mm
SP252 - ch. 6,35mm - 2,345kg



ENCAIXE DO FUEIRO SUPERIOR
SP246.2 - ch. 3,75mm - 1,160kg

CARRETAS LINHA ALUPLAST A PARTIR DE 2016



GRADE DO TOMBADOR SUPERIOR 2016

GR106	650x2430mm
GR106A	700x2430mm
GR106B	800x2430mm
GR106D	1000x2430mm

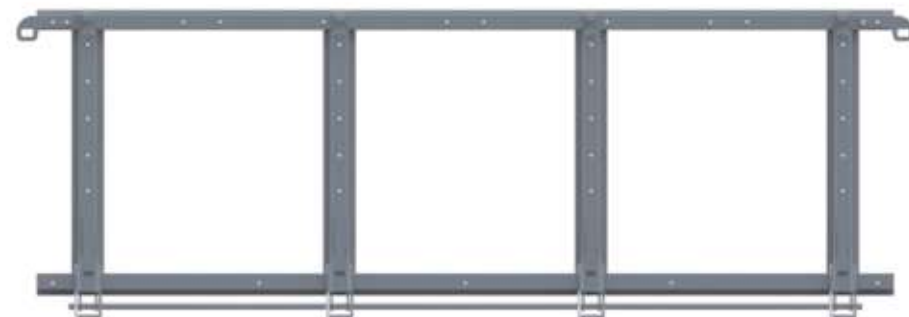

GRADE DO TOMBADOR INFERIOR 2016

GR107	650x2430mm
GR107A	700x2430mm
GR107B	800x2430mm
GR107D	1000x2430mm

GRADE TRASEIRA CARGA SECA 2016

GR107Z	550x2430mm
---------------	------------



GRADE LATERAL SUPERIOR BITREM 7,10m - 2016

GR131	650x2190mm
GR131A	700x2190mm
GR131B	800x2190mm
GR131D	1000x2190mm

GRADE LATERAL SUPERIOR CARRETA 2016

GR104	650x2970mm
GR104A	700x2970mm
GR104B	800x2970mm
GR104D	1000x2970mm

GRADE LATERAL SUPERIOR RODOTREM 9,50m - 2016

GR137	650x2995mm
GR137A	700x2995mm
GR137B	800x2995mm
GR137D	1000x2995mm

GRADE LATERAL SUPERIOR CARRETA 13,50m 5 TAMPAS

GR135	650x2535mm
GR135A	700x2535mm
GR135B	800x2535mm
GR135D	1000x2535mm

GRADE LATERAL SUPERIOR CARRETA 11,60m 2016

GR132	650x2735mm
GR132A	700x2735mm
GR132B	800x2735mm
GR132D	1000x2735mm



GRADE LATERAL INFERIOR BITREM 7,10m - 2016

GR133	650x2190mm
GR133A	700x2190mm
GR133B	800x2190mm
GR133D	1000x2190mm

GRADE LATERAL INFERIOR CARRETA 2016

GR105	650x2970mm
GR105A	700x2970mm
GR105B	800x2970mm
GR105D	1000x2970mm

GRADE LATERAL INFERIOR RODOTREM 9,50m - 2016

GR138	650x2995mm
GR138A	700x2995mm
GR138B	800x2995mm
GR138D	1000x2995mm

GRADE LATERAL INFERIOR CARRETA 13,50m 5 TAMPAS

GR136	650x2535mm
GR136A	700x2535mm
GR136B	800x2535mm
GR136D	1000x2535mm

GRADE LATERAL CARGA SECA 2016

GR105Z	550x2970mm
---------------	------------

GRADE LATERAL INFERIOR CARRETA 11,60m 2016

GR134	650x2735mm
GR134A	700x2735mm
GR134B	800x2735mm
GR134D	1000x2735mm



CONJUNTO DO TOMBADOR INFERIOR DA CARRETA 2016

SP760	- 7,300kg
(02 unidades)	

INFORMAÇÕES



RANDON | CAIXA DE CARGA BITREM 7 EIXOS 7,10m



RANDON | CAIXA DE CARGA BITREM 7 EIXOS 7,50m

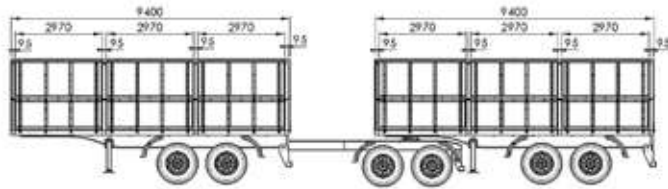

RANDON | CAIXA DE CARGA RODOTREM 9 EIXOS 9,40m

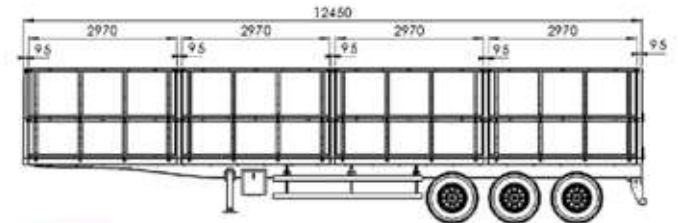

RANDON | CAIXA DE CARGA SEMIRREBOQUE 3 EIXOS 12,50m

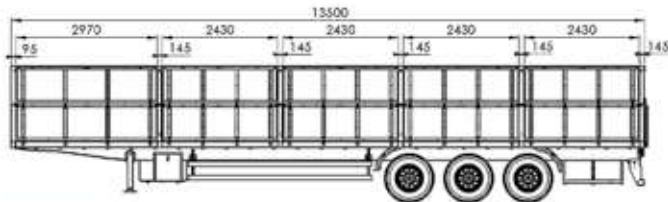

RANDON | CAIXA DE CARGA SEMIRREBOQUE 3 EIXOS 13,50m

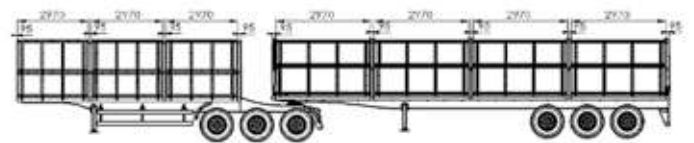

RANDON | CAIXA DE CARGA BITRENÇÃO 9 EIXOS 9,40m + 12,50m



GUERRA | CAIXA DE CARGA BITREM 7 EIXOS 7,10m



GUERRA | CAIXA DE CARGA RODOTREM 9 EIXOS 9,40m

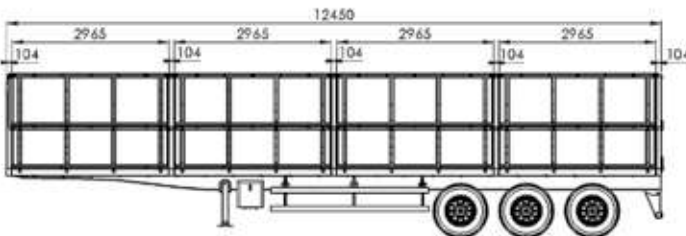

GUERRA | CAIXA DE CARGA SEMIRREBOQUE 3 EIXOS 12,50m

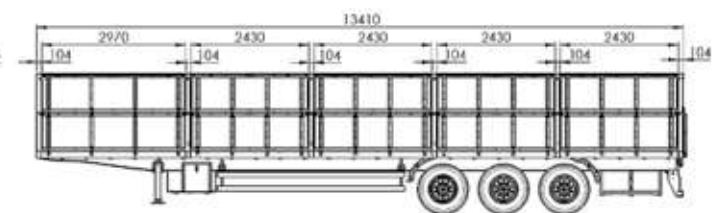

GUERRA | CAIXA DE CARGA SEMIRREBOQUE 3 EIXOS 13,50m



NOMA | CAIXA DE CARGA BITREM 7 EIXOS 7,10m



NOMA | CAIXA DE CARGA BITREM 7 EIXOS 7,50m

INFORMAÇÕES



NOMA | CAIXA DE CARGA RODOTREM 9 EIXOS 9,40m

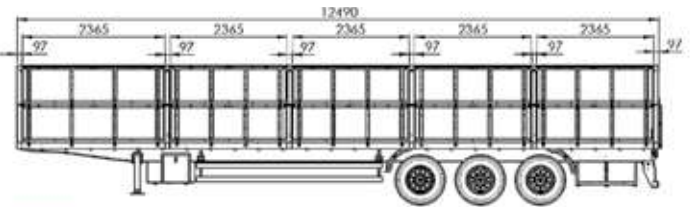

NOMA | CAIXA DE CARGA SEMIRREBOQUE 3 EIXOS 12,50m

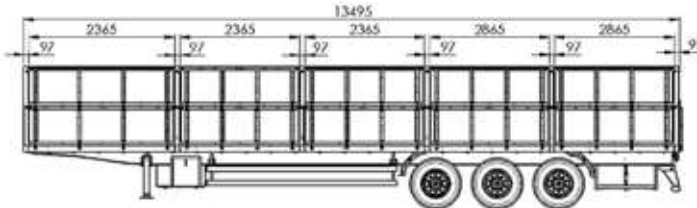

NOMA | CAIXA DE CARGA SEMIRREBOQUE 3 EIXOS 13,50m

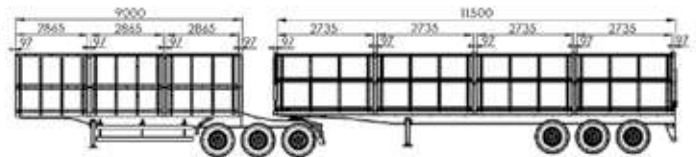

NOMA | CAIXA DE CARGA BITRENÇÃO 9 EIXOS 9,40m + 11,50m



LIBRELATO | CAIXA DE CARGA BITREM 7 EIXOS 7,10m



LIBRELATO | CAIXA DE CARGA BITREM 7 EIXOS 7,50m

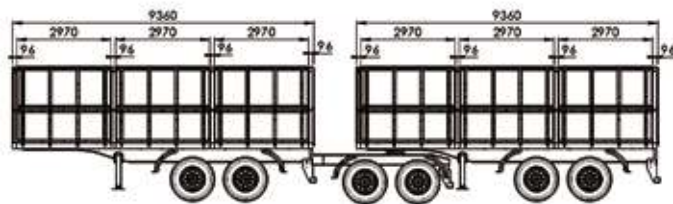

LIBRELATO | CAIXA DE CARGA RODOTREM 9 EIXOS 9,40m

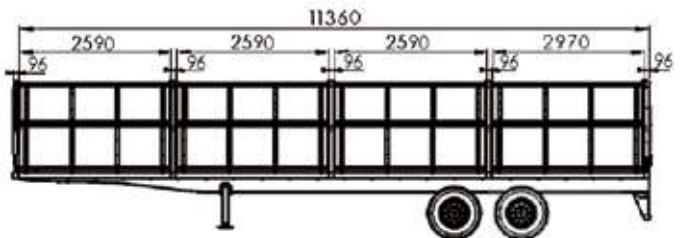

LIBRELATO | CAIXA DE CARGA SEMIRREBOQUE 2 EIXOS 11,50m

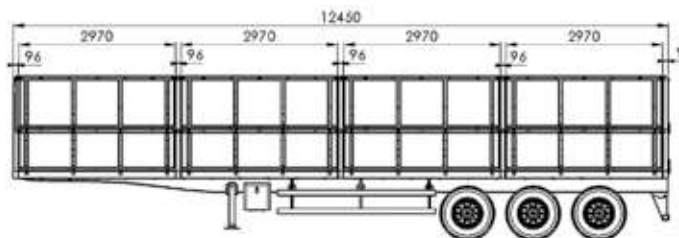

LIBRELATO | CAIXA DE CARGA SEMIRREBOQUE 3 EIXOS 12,50m

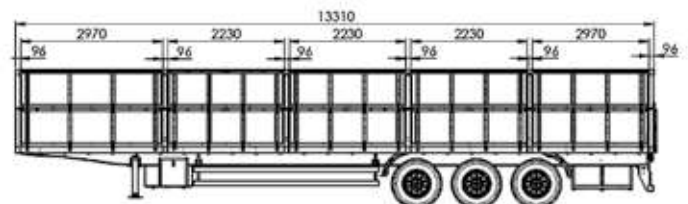

LIBRELATO | CAIXA DE CARGA SEMIRREBOQUE 3 EIXOS 13,50m

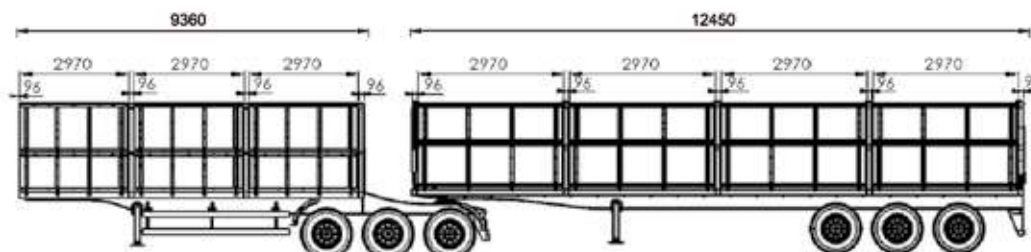

LIBRELATO | CAIXA DE CARGA BITRENÇÃO 9 EIXOS 9,50m + 12,50m

INFORMAÇÕES



FACCHINI | CAIXA DE CARGA BITREM 7 EIXOS 7,10m

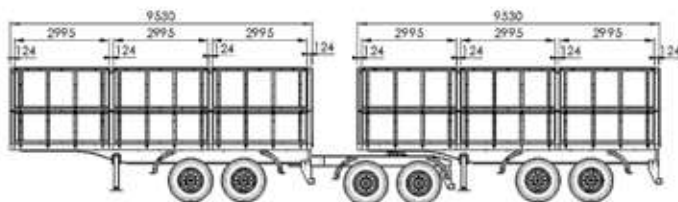

FACCHINI | CAIXA DE CARGA RODOTREM 9 EIXOS 9,50m

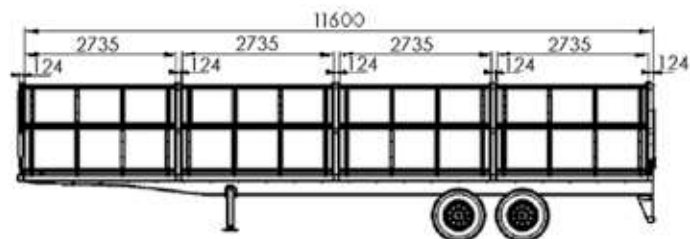

FACCHINI | CAIXA DE CARGA SEMIRREBOQUE 2 EIXOS 11,60m

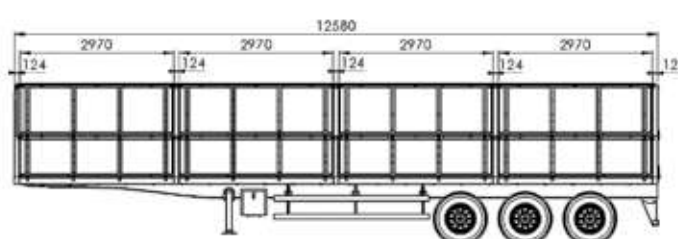

FACCHINI | CAIXA DE CARGA SEMIRREBOQUE 3 EIXOS 12,50m

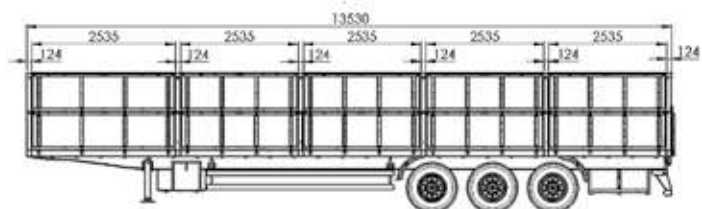

FACCHINI | CAIXA DE CARGA SEMIRREBOQUE 3 EIXOS 13,50m

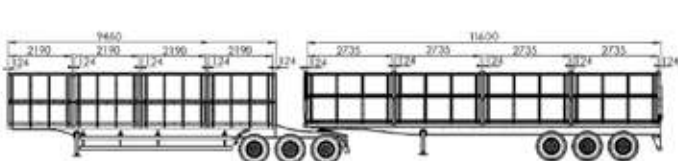

FACCHINI | CAIXA DE CARGA BITRENÇÃO 9 EIXOS 9,50m + 11,60m

 **+55 (54) 3291.5159**

 +55 (54) 99100.2899

+55 (54) 99305.3448

+55 (54) 99235.0308

 metalc@metalc.com.br

 /metalc.componentes

 /metalccomponentes

 **Rua Pe. Feijó, 1144 | Centro**
São Marcos | RS | Brasil

www.metalc.com.br



METAL C
COMPONENTES AUTOMOTIVOS